

**Council Members**

Roger Manning-Mayor  
Katrina Long Robinson-Vice Mayor  
John Stanavitch-Seat 1  
Kara Crump-Seat 2  
Phillip Everett-Seat 3



**City of Westlake**

4001 Seminole Pratt Whitney Rd.  
Westlake, Florida 33470  
Phone: 561-530-5880  
Fax: 561-790-5466

**Regular Meeting and Public Hearing**

**Monday, October 8, 2018**

**Meeting Location**

**Westlake Council Chambers**

**4005 Seminole Pratt-Whitney Road**

**Westlake, FL 33470**

**6:30 PM**

*PLEASE TAKE NOTICE AND BE ADVISED, that if any interested person desires to appeal any decision made by the City Council with respect to any matter considered at this meeting or hearing, such interested person will need a record of the proceedings and for such purpose may need to ensure that a verbatim record of the proceedings is made, which record includes the testimony and evidence upon which the appeal is to be based. The meeting/hearing may be continued to another date and time as may be found necessary during the aforesaid meeting. In accordance with the provisions of the Americans with Disabilities Act (ADA), any person requiring special accommodations at these meetings because of disability or physical impairment should contact the Interim City Manager at (954)753-5841 at least two (2) calendar days prior to the meeting.*

**City of Westlake**

4001 Seminole Pratt Whitney Rd.  
Westlake, Florida 33470  
Phone: 561-530-5880  
Fax: 561-790-5466  
Website: [westlakegov.com](http://westlakegov.com)



**Council Members**

Roger Manning-Mayor  
Katrina Long Robinson-Vice Mayor  
John Stanavitch-Seat 1  
Kara Crump-Seat 2  
Phillip Everett-Seat 3

October 5, 2018

City Council  
City of Westlake

Dear Mayor and Council:

The City Council of the City of Westlake will hold a regular meeting and public hearing on Monday, October 8, 2018 at 6:30 p.m. at the Westlake Council Chambers, 4005 Seminole Pratt Whitney Road, Westlake, Florida. Following is the advance agenda for the meeting.

1. Call to Order/ Roll Call
2. Pledge of Allegiance
3. Approval of Agenda
4. Audience Comments on Agenda Items (3) Minute Time Limit
5. Approval of the Minutes of the September 10 and September 24, 2018 Meetings
6. Approval of Financial Statements for August 2018
7. Consideration of Engagement Letter with Berger, Toombs, Elam, Gaines & Frank for Fiscal Year 2018

**FIRST READING OF ORDINANCE**

8. Ordinance 2019-1 – Flood Plan Management FEMA

**PUBLIC HEARING TO APPROVE PLAT**

9. Resolution 2018-28 – Approving the Final Plat for Waters Edge Drive

**CLOSE PUBLIC HEARING**

10. PBSO Monthly Report – Informational Only
11. Response Time Report from Palm Beach County Fire Rescue – Informational Only
12. Manager’s Report
13. Attorney’s Report
14. Audience Comments on Other Items (3) Minute Time Limit
15. Council Comments
16. Adjournment

Any additional supporting material for the items listed above, not included in the agenda package, will be distributed at the meeting. Staff will present their reports at the meeting. I look forward to seeing you, but in the meantime if you have any questions, please contact me.

Sincerely,

*Kenneth Cassel*

Kenneth G. Cassel  
City Manager

cc: Pam E. Booker, Esq.  
Terry Lewis  
John Carter  
Kelley Burke

## **Fifth Order of Business**

**MINUTES OF MEETING  
CITY OF WESTLAKE**

A meeting of the City Council of the City of Westlake was held on Monday, September 10, 2018, at 6:30 p.m., at the Westlake Community Center, 4005 Seminole-Pratt Whitney Road, Westlake, Florida.

Present and constituting a quorum were:

|                      |                     |
|----------------------|---------------------|
| Roger Manning        | Mayor               |
| Karina Long Robinson | Vice Mayor          |
| John Stanavitch      | City Council Seat 1 |
| Kara Crump           | City Council Seat 2 |
| Phillip Everett      | City Council Seat 3 |

Also present were:

|                |                               |
|----------------|-------------------------------|
| Kenneth Cassel | City Manager                  |
| Pam Ryan       | Attorney                      |
| Alan Baldwin   | Inframark, Accounting Manager |
| Nilsa Zacarias | NZ Consultants                |
| Don Hearing    | Coutleur & Hearing            |
| John Carter    | Minto PBLH                    |
| Elliot Cohen   | My PR Guru                    |

*The following is a summary of the minutes and actions taken during the September 10, 2018 City of Westlake Council Meeting.*

**FIRST ORDER OF BUSINESS**

**Call to Order/Roll Call**

Mayor Manning called the meeting to order and Mr. Cassel called the roll.

**SECOND ORDER OF BUSINESS**

**Pledge of Allegiance**

The Pledge of Allegiance was recited.

**THIRD ORDER OF BUSINESS**

**Approval of Agenda**

On MOTION by Councilman Everett seconded by Vice Mayor Long Robinson with all in favor the agenda was approved.

**FOURTH ORDER OF BUSINESS**

**Audience Comments on Agenda Items (3)  
Minute Time Limit**

There being none, the next item followed.

**FIFTH ORDER OF BUSINESS**

**Approval of Minutes of the August 13, 2018 Meeting**

On MOTION by Councilman Stanavitch seconded by Councilwoman Crump with all in favor the minutes of the August 13, 2018 meeting were approved.

**SIXTH ORDER OF BUSINESS**

**Approval of Financial Statements for July 2018**

On MOTION by Councilman Everett seconded by Councilman Stanavitch with all in favor the financial statements for July 2018 were approved.

**SEVENTH ORDER OF BUSINESS**

**Release of Unity Title – Official Records Book 2865, Page 744**

Mr. Carter addressed the Council and provided an overview of the release of unity titles on the agenda. In order for the plat efforts associated with the packing house to proceed, which is where some of the original residential structures are located, these old unity titles need to be released.

Ms. Ryan stated the issue was done for a worst case scenario to make sure the uses of the residences were permitted. Release of those titles is now appropriate because it is no longer necessary for them to be compliant with the City’s Code and Comprehensive Plan.

On MOTION by Vice Mayor Long Robinson seconded by Councilman Stanavitch with all in favor the Release of Unity Title – Official Records Book 2865, Page 744, was approved.

**EIGHTH ORDER OF BUSINESS**

**Release of Unity Title – Official Records Book 7818, Page 1681**

On MOTION by Councilwoman Crump seconded by Councilman Everett with all in favor Release of Unity Title – Official Records Book 7818, Page 1681, was approved.

**NINTH ORDER OF BUSINESS**

**Public Relations Presentation – Elliot Cohen**

Mr. Cohen provided the Council with a presentation on the services his company provides for municipal communications.

**TENTH ORDER OF BUSINESS**

**Resolution 2018-16 – Approving  
Meadows of Westlake Phase 1 Plat**

Mr. Cassel stated this item was tabled at the last meeting due to minor changes on the perimeters.

Mr. Hearing provided an overview of the changes made to the perimeters associated with the Meadows of Westlake Phase 1 Plat.

Mr. Cassel read Resolution 2018-16 by title only.

On MOTION by Councilwoman Crump seconded by Councilman Everett with all in favor Resolution 2018-16, approving the Meadows of Westlake Phase 1 Plat, was adopted.

**ELEVENTH ORDER OF BUSINESS**

**Resolution 2018-20 – Approving Del  
Webb at Westlake Plat**

Ms. Zacarias provided the Council with a presentation on the subdivision plan associated with Del Webb at Westlake Plat.

Mr. Hearing also provided an overview of the Del Webb at Westlake Plat.

Mr. Carter addressed the Counsel regarding the Del Webb at Westlake subdivision, which will be an active adult community developed by Pulte.

Vice Mayor Long Robinson expressed concern that an active adult community may run the risk of foreclosures.

Mr. Cassel read Resolution 2018-20 by title only.

On MOTION by Councilman Stanavitch seconded by Councilman Everett with Mayor Manning, Councilman Stanavitch, Councilwoman Crump and Councilman Everett voting aye and Vice Mayor Long Robinson voting nay, Resolution 2018-20, approving Del Webb at Westlake Plat, was adopted.

**TWELFTH ORDER OF BUSINESS**

**Proposed Budget for Fiscal Year Ending  
September 30, 2019**

Mr. Cassel reviewed changes made to the proposed budget.

- Legal Counsel was increased by \$60,000. This will be taken from the future City Hall line item.
- He recommended reducing the City Hall line item to \$50,000 and provided options for an alternate approach.

**A. Resolution 2018-21 – Approving the Proposed Millage Rate**

Mr. Cassel read Resolution 2018-21 by title only.

On MOTION by Councilwoman Crump seconded by Vice Mayor Long Robinson with all in favor Resolution 2018-21, approving the proposed millage rate for Fiscal Year 2019, was adopted.

**B. Resolution 2018-22 – Approving the Proposed Budget**

Two line items were changed in the proposed budget presented in the agenda package.

*Legal Counsel* was increased by \$60,000 and *City Hall* was decreased by \$50,000.

Mr. Cassel read Resolution 2018-22 by title only.

On MOTION by Vice Mayor Long Robinson seconded by Councilman Everett with all in favor Resolution 2018-22, approving the proposed budget as amended, was adopted.

The public hearing was closed.

**THIRTEENTH ORDER OF BUSINESS**

**Resolution 2018-23 – Celebrating 50 Years of Home Rule**

Mr. Cassel read Resolution 2018-23 by title only.

Mayor Manning provided an overview of the resolution. This resolution provides support in the effort to challenge efforts being made to reduce municipalities’ rights to self-govern.

On MOTION by Councilman Stanavitch seconded by Vice Mayor Long Robinson with all in favor Resolution 2018-23, celebrating 50 years of Home Rule, was adopted.

**FOURTEENTH ORDER OF BUSINESS**

**Consideration of Meeting Schedule for Fiscal Year 2019**

The Council reviewed the proposed meeting schedule and changed the November date to November 19, 2018.

On MOTION by Councilwoman Crump seconded by Councilman Everett with all in favor the meeting schedule for Fiscal Year 2019 was approved as amended.

**FIFTEENTH ORDER OF BUSINESS**

**PBSO Monthly Report – Informational Only**

Vice Mayor Long Robinson stated the Principle of Seminole Ridge High School sent an email regarding traffic issues they are having. Mr. Cassel will contact Dr. Campbell to discuss the issues.

**SIXTEENTH ORDER OF BUSINESS**

**Manager’s Report**

The following was discussed:

- Mr. Cassel reported on the meeting he attended with Mayor Manning of the Western Communities Council. They are asking the various entities who are members to confirm whether they want to continue with the Western Communities Council or dissolve. Mayor Manning and Mr. Cassel both agree it is a good idea for the Western Communities Council to continue.
- Mr. Cassel noted the final number on the resolution for the proposed budget is \$3,286,000 and the next public hearing will be September 24, 2018.
- Seminole Pratt Whitney Road is open and the final striping will begin this week.
- FP&L is installing poles along the M-2 Canal area. They are also working on their undergrounding from the substation into the main feeds.

**SEVENTEENTH ORDER OF BUSINESS**

**Attorney’s Report**

There being nothing additional to report, the next item followed.

**EIGHTEENTH ORDER OF BUSINESS**

**Audience Comments on Other Items (3) Minute Time Limit**

There being none, the next item followed.

**NINETEENTH ORDER OF BUSINESS**

**Council Comments**

The following comments were made:

- Vice Mayor Long Robinson stated a lobbyist contacted her because the City was on the County’s agenda regarding the Solid Waste Authority. The lobbyist wanted to know if the City planned on staying with the Solid Waste Authority after the significant rate increase. Mr. Cassel responded they extended the contract and the City will continue to use Solid Waste Authority for the next year, at which time the City will decide what to do about the solid waste contract.
- Vice Mayor Long Robinson and Mayor Manning attended the Mayor’s Literacy Luncheon. It is a partnership the Literacy Coalition has with municipalities to help



increase literacy. Seminole Ridge High School does not fall under the category of needing to increase their literacy rate.

- Mayor Manning discussed the Florida League of Cities conference he attended. It was a great opportunity to meet other municipal members and attorneys.

**TWENTIETH ORDER OF BUSINESS                      Adjournment**

There being no further business, the meeting adjourned at 7:56 p.m.

---

Kenneth Cassel  
City Manager

---

Roger Manning  
Mayor

**MINUTES OF MEETING  
CITY OF WESTLAKE**

A meeting and public hearing of the City Council of the City of Westlake was held on Monday, September 24, 2018, at 6:30 p.m., at the Westlake Community Center, 4005 Seminole-Pratt Whitney Road, Westlake, Florida.

Present and constituting a quorum were:

|                      |                     |
|----------------------|---------------------|
| Roger Manning        | Mayor               |
| Karina Long Robinson | Vice Mayor          |
| John Stanavitch      | City Council Seat 1 |
| Kara Crump           | City Council Seat 2 |

Also present were:

|                |                      |
|----------------|----------------------|
| Kenneth Cassel | City Manager         |
| Pam Booker     | City Attorney        |
| Tara Duh       | Louis Longman-Walker |
| John Carter    | Minto PBLH           |

*The following is a summary of the minutes and actions taken during the September 24, 2018 City of Westlake Council Meeting.*

**FIRST ORDER OF BUSINESS**

**Call to Order/Roll Call**

Mayor Manning called the meeting to order and Mr. Cassel called the roll.

**SECOND ORDER OF BUSINESS**

**Pledge of Allegiance**

The Pledge of Allegiance was recited.

**THIRD ORDER OF BUSINESS**

**Approval of Agenda**

|   |
|---|
| On MOTION by Vice Mayor Long-Robinson seconded by Councilwoman Crump with all in favor the agenda was approved. |
|---|

**FOURTH ORDER OF BUSINESS**

**Audience Comments on Agenda Items (3)  
Minute Time Limit**

There being none, the next item followed.

**FIFTH ORDER OF BUSINESS**

**Approval of Resolution 2018-24  
Approving the Final School Site Plat**

The following was discussed:

- Ms. Duhy provided information why these are coming before the Council at this time.
- Mr. Carter indicated the Plat reserves the parcel of Minto PBLH as the owner. By deed Minto PBLH will convey the parcel that has been platted to the School Board as part of the Deed Conveyance.

Mr. Cassel read Resolution 2018-24 by title only.

On MOTION by Councilwoman Crump seconded by Vice Mayor Long-Robinson with all in favor Resolution 2018-24, approving the final school site plat, was adopted.

**SIXTH ORDER OF BUSINESS**

**Approval of Resolution 2018-25  
Approving the Final Plat for Persimmon  
Boulevard East, Plat 2**

The following was discussed:

- Ms. Duhy presented a companion to the previous item as part of the School District parcel.
- We were required to provide access making it necessary to revise the Plat to continue the Plat of Persimmon Phase 1 which has been approved.
- Attorney Pam Booker indicated at the Seminole Improvement Board Meeting there were a couple of changes to it making a request that the Resolution be approved with those changes.

Mr. Cassel read Resolution 2018-25 by title only.

On MOTION by Councilman Stanavitch seconded by Vice Mayor Long-Robinson with all in favor Resolution 2018-25, approving the final plat for Persimmon Boulevard East, was adopted with SID's amendments.

**SEVENTH ORDER OF BUSINESS**

**Proposed Budget for Fiscal Year Ending  
September 30, 2019**

**A. Resolution 2018-26, Adopting the Final Millage Rate**

Mr. Cassel read Resolution 2018-26 by title only.

On MOTION by Vice Mayor Long-Robinson seconded by Councilman Stanavitch with all in favor Resolution 2018-26, adopting the final millage rate, was adopted.

**B. Resolution 2018-27, Adopting the Final Budget**

Mr. Cassel read Resolution 2018-27 by title only.

On MOTION by Councilwoman Crump, seconded by Vice-Mayor Long-Robinson with all in favor Resolution 2018-27, adopting the final budget, was adopted.

The public hearing was closed.

**EIGHTH ORDER OF BUSINESS**

**Reconsideration of Meeting Schedule for Fiscal Year 2019**

The Council reviewed the meeting schedule and changed the November meeting date to November 12, 2018.

On MOTION by Councilwoman Crump, seconded by Councilman Stanavitch with all in favor the meeting schedule was approved as amended.

**NINTH ORDER OF BUSINESS**

**Manager’s Report**

Mr. Cassel reported the following:

- SID is requesting a joint meeting with the Council. Discussion ensued and there was consensus to hold the joint meeting on October 17, 2018 at 6:00 p.m. Mr. Cassel will confirm with the SID Board for their availability.
- He met with Dr. Campbell from the School to discuss their emergency evacuation plans. They also had questions regarding traffic. Mr. Cassel reached out to the Police Department to assist with parents not dropping off their kids in the middle of the street.
- Discussion ensued regarding the power poles.

**TENTH ORDER OF BUSINESS**

**Attorney’s Report**

Ms. Booker reported staff is working on a flood ordinance for the City.

**ELEVENTH ORDER OF BUSINESS**

**Audience Comments on Other Items (3)  
Minute Time Limit**

Mr. Carter provided an update on development within the City.

**TWELFTH ORDER OF BUSINESS**

**Council Comments**

There being none, the next item followed.

**THIRTEENTH ORDER OF BUSINESS                      Adjournment**

There being no further business, the meeting adjourned at 7:56 p.m.

---

Kenneth Cassel  
City Manager

---

Roger Manning  
Mayor

## **Sixth Order of Business**



## MEMORANDUM

**TO:** Members of the City Council, City of Westlake  
**FROM:** Steven Fowler, Accountant II; Alan Baldwin, Accounting Manager  
**CC:** Ken Cassel, City Manager  
**DATE:** October 3, 2018  
**SUBJECT:** August Financial Report

---

Please find attached the August 2018 financial report. During your review, please keep in mind that the goal is for revenue to meet or exceed the year-to-date budget and for expenditures to be at or below the year-to-date budget. An overview of the City is provided below. Should you have any questions or require additional information, please contact me at [Steven.Fowler@inframark.com](mailto:Steven.Fowler@inframark.com).

### **General Fund**

- Total Revenues through August were approximately 109% of the annual budget, which is primarily the result of unanticipated fees from Building, Engineering and Planning/Zoning permits. Total Revenue also includes revenue from a funding agreement with Minto Community LLC. (Developer). 100% of Ad Valorem Tax have been collected. However, the Palm Beach County Value Adjustment Board has reduced the City's FY2018 taxable value in response to a petition from a taxpayer. The result of this will be a reduction in tax receipts, which will be reflected in the September financial statements.
- Total Expenditures through August were approximately 100% of the annual budget. This is principally due to Building Department costs which were higher than anticipated.

### **Special Revenue Fund – Housing Assistance Program**

- A budget amendment was approved in January.

# City of Westlake

## Financial Report

*August 31, 2018*





## Table of Contents

| <b><u>FINANCIAL STATEMENTS</u></b>                              | Page # |
|---|--------|
| Balance Sheet .....   | 1      |
| Statement of Revenues, Expenditures and Changes in Fund Balance |        |
| General Fund .....  | 2 - 3  |
| Special Revenue Fund (Housing Assistance Program) .....         | 4      |
| <b><u>SUPPORTING SCHEDULES</u></b>                              |        |
| Cash and Investment Report .....                                | 5      |
| Bank Reconciliation .....                                       | 6      |
| Check Register .....  | 7 - 8  |

# **City of Westlake**

## **Financial Statements**

**August 31, 2018**

**Balance Sheet**  
August 31, 2018

| ACCOUNT DESCRIPTION                           | GENERAL<br>FUND   | SPECIAL<br>REVENUE<br>FUND -<br>HOUSING<br>ASSISTANCE<br>PROGRAM | TOTAL               |
|---|-------------------|--|---------------------|
| <b><u>ASSETS</u></b>                          |                   |  |                     |
| Cash - Checking Account                       | \$ 567,528        | \$ -   | \$ 567,528          |
| Due From Other Gov'tl Units                   | 12,499            | -  | 12,499              |
| Due From Other Districts                      | 2,281             | -  | 2,281               |
| Other Receivables                             | 4,535             | -  | 4,535               |
| Due From Other Funds                          | 10,000            | -  | 10,000              |
| Investments:                                  |                   |  |                     |
| Money Market Account                          | 87,209            | 280,772  | 367,981             |
| Prepaid Items                                 | 159,640           | -  | 159,640             |
| Deposits                                      | 100               | -  | 100                 |
| <b>TOTAL ASSETS</b>                           | <b>\$ 843,792</b> | <b>\$ 280,772</b>  | <b>\$ 1,124,564</b> |
| <b><u>LIABILITIES</u></b>                     |                   |  |                     |
| Accounts Payable                              | \$ 136,376        | \$ -   | \$ 136,376          |
| Accrued Expenses                              | 45,000            | -  | 45,000              |
| DBPR surcharge                                | 4,935             | -  | 4,935               |
| BRA surcharge                                 | 7,454             | -  | 7,454               |
| Deferred Revenue-Developer Submittals (Minto) | 100,000           | -  | 100,000             |
| Due To Other Funds                            | -                 | 10,000   | 10,000              |
| <b>TOTAL LIABILITIES</b>                      | <b>293,765</b>    | <b>10,000</b>  | <b>303,765</b>      |
| <b><u>FUND BALANCES</u></b>                   |                   |  |                     |
| <b>Nonspendable:</b>                          |                   |  |                     |
| Prepaid Items                                 | 159,640           | -  | 159,640             |
| <b>Restricted for:</b>                        |                   |  |                     |
| Special Revenue                               | -                 | 270,772  | 270,772             |
| <b>Unassigned:</b>                            | 390,387           | -  | 390,387             |
| <b>TOTAL FUND BALANCES</b>                    | <b>\$ 550,027</b> | <b>\$ 270,772</b>  | <b>\$ 820,799</b>   |
| <b>TOTAL LIABILITIES &amp; FUND BALANCES</b>  | <b>\$ 843,792</b> | <b>\$ 280,772</b>  | <b>\$ 1,124,564</b> |

**Statement of Revenues, Expenditures and Changes in Fund Balances**  
For the Period Ending August 31, 2018

| ACCOUNT DESCRIPTION            | AMENDED BUDGET   | YEAR TO DATE BUDGET | YEAR TO DATE ACTUAL | VARIANCE (\$) FAV(UNFAV) |
|--------------------------------|------------------|---------------------|---------------------|--------------------------|
| <b>REVENUES</b>                |                  |                     |                     |                          |
| Interest - Investments         | \$ 2,000         | \$ 1,833            | \$ 879              | \$ (954)                 |
| Ad Valorem Taxes               | 138,030          | 138,030             | 140,208             | 2,178                    |
| Ad Valorem Taxes - Discounts   | (5,521)          | (5,521)             | (5,463)             | 58                       |
| Local Option Gas Tax           | -                | -                   | 77                  | 77                       |
| FPL Franchise                  | -                | -                   | 11,834              | 11,834                   |
| Electricity                    | -                | -                   | 5,578               | 5,578                    |
| Water                          | -                | -                   | 12,499              | 12,499                   |
| Communication Services Taxes   | -                | -                   | 8,189               | 8,189                    |
| Occupational Licenses          | 5,000            | 4,583               | 1,160               | (3,423)                  |
| Building Permits               | 160,000          | 146,667             | 517,494             | 370,827                  |
| Building Permits - Surcharge   | -                | -                   | 1,342               | 1,342                    |
| Other Building Permit Fees     | -                | -                   | 421,448             | 421,448                  |
| Building Permits - Admin Fee   | -                | -                   | 18,210              | 18,210                   |
| Miscellaneous Plan Review      | -                | -                   | 101,660             | 101,660                  |
| Other Licenses, Fees & Permits | -                | -                   | 3,240               | 3,240                    |
| Local Govt .05c Sales Tax      | 1,000            | 917                 | 8                   | (909)                    |
| Recording Fees                 | -                | -                   | 93                  | 93                       |
| Administrative Fees            | -                | -                   | 40,753              | 40,753                   |
| Judgements and Fines           | -                | -                   | 99                  | 99                       |
| Interest - Tax Collector       | -                | -                   | 9                   | 9                        |
| Other Impact Fees              | 1,500            | 1,500               | -                   | (1,500)                  |
| Developer Contribution         | 1,580,967        | 1,580,967           | 769,568             | (811,399)                |
| Lien Search Fee                | -                | -                   | 285                 | 285                      |
| Inspection Fees                | 1,000            | 917                 | 2,850               | 1,933                    |
| <b>TOTAL REVENUES</b>          | <b>1,883,976</b> | <b>1,869,893</b>    | <b>2,052,020</b>    | <b>182,127</b>           |

**EXPENDITURES**

**Administration**

|                                |         |         |         |           |
|--------------------------------|---------|---------|---------|-----------|
| Mayor/Council Stipend          | 204,000 | 187,000 | 187,000 | -         |
| FICA Taxes                     | 15,606  | 14,306  | 14,306  | -         |
| ProfServ-Engineering           | 100,000 | 91,667  | 139,137 | (47,470)  |
| ProfServ-Legal Services        | 284,280 | 260,590 | 267,105 | (6,515)   |
| ProfServ-Legislative Expense   | 18,000  | 16,500  | 22,000  | (5,500)   |
| ProfServ-Planning/Zoning Board | 170,000 | 155,833 | 202,077 | (46,244)  |
| ProfServ-Consultants           | 40,000  | 36,667  | 17,150  | 19,517    |
| ProfServ-Building Permits      | 160,000 | 146,667 | 545,874 | (399,207) |
| Management Services            | 283,830 | 260,178 | 318,952 | (58,774)  |
| ProfServ-Web Site Maintenance  | 5,900   | 5,408   | 4,658   | 750       |

**Statement of Revenues, Expenditures and Changes in Fund Balances**  
For the Period Ending August 31, 2018

| ACCOUNT DESCRIPTION                          | AMENDED BUDGET    | YEAR TO DATE BUDGET | YEAR TO DATE ACTUAL | VARIANCE (\$) FAV(UNFAV) |
|--|-------------------|---------------------|---------------------|--------------------------|
| Auditing Services                            | 7,000             | 3,500               | 3,085               | 415                      |
| Communication - Telephone                    | 7,500             | 6,875               | 3,521               | 3,354                    |
| Postage and Freight                          | 1,500             | 1,375               | 1,250               | 125                      |
| Lease - Building                             | 500               | 500                 | 500                 | -                        |
| Insurance - General Liability                | 15,000            | 15,000              | 6,000               | 9,000                    |
| Printing and Binding                         | 1,000             | 917                 | -                   | 917                      |
| Legal Advertising                            | 10,000            | 9,167               | 21,847              | (12,680)                 |
| General Government                           | 33,360            | 30,580              | 45,200              | (14,620)                 |
| Council Expenses                             | 10,000            | 9,167               | -                   | 9,167                    |
| Misc-Contingency                             | 90,000            | 82,500              | 22,562              | 59,938                   |
| Office Supplies                              | 2,500             | 2,292               | 5,842               | (3,550)                  |
| Dues, Licenses, Subscriptions                | 9,000             | 8,250               | 4,918               | 3,332                    |
| Cap Outlay - Office Computers                | 20,000            | 18,333              | -                   | 18,333                   |
| Cap Outlay - Software                        | 120,000           | 110,000             | -                   | 110,000                  |
| <b>Total Administration</b>                  | <b>1,608,976</b>  | <b>1,473,272</b>    | <b>1,832,984</b>    | <b>(359,712)</b>         |
| <b>Other Public Safety</b>                   |                   |                     |                     |                          |
| Contracts-Sheriff                            | 275,000           | 252,083             | 41,987              | 210,096                  |
| Misc-Contingency                             | -                 | -                   | 4,966               | (4,966)                  |
| <b>Total Other Public Safety</b>             | <b>275,000</b>    | <b>252,083</b>      | <b>46,953</b>       | <b>205,130</b>           |
| <b>TOTAL EXPENDITURES</b>                    | <b>1,883,976</b>  | <b>1,725,355</b>    | <b>1,879,937</b>    | <b>(154,582)</b>         |
| Excess (deficiency) of revenues              |                   |                     |                     |                          |
| Over (under) expenditures                    | -                 | 144,538             | 172,083             | 27,545                   |
| Net change in fund balance                   | \$ -              | \$ 144,538          | \$ 172,083          | \$ 27,545                |
| <b>FUND BALANCE, BEGINNING (OCT 1, 2017)</b> | <b>377,944</b>    | <b>377,944</b>      | <b>377,944</b>      |                          |
| <b>FUND BALANCE, ENDING</b>                  | <b>\$ 377,944</b> | <b>\$ 522,482</b>   | <b>\$ 550,027</b>   |                          |

**Statement of Revenues, Expenditures and Changes in Fund Balances**  
For the Period Ending August 31, 2018

| ACCOUNT DESCRIPTION  | AMENDED<br>BUDGET | YEAR TO DATE<br>BUDGET | YEAR TO DATE<br>ACTUAL | VARIANCE (\$)<br>FAV(UNFAV) |
|--|-------------------|------------------------|------------------------|-----------------------------|
| <b><u>REVENUES</u></b>                                       |                   |                        |                        |                             |
| Interest - Investments                                       | \$ -              | \$ -                   | \$ 2,056               | \$ 2,056                    |
| Developer Contribution                                       | 316,500           | 316,500                | 316,500                | -                           |
| Donations  | -                 | -                      | 9,000                  | 9,000                       |
| <b>TOTAL REVENUES</b>  | <b>316,500</b>    | <b>316,500</b>         | <b>327,556</b>         | <b>11,056</b>               |
| <b><u>EXPENDITURES</u></b>                                   |                   |                        |                        |                             |
| <b><u>Administration</u></b>                                 |                   |                        |                        |                             |
| Misc-Admin Fee (%)   | 22,155            | 20,309                 | -                      | 20,309                      |
| Assistance Program   | 294,345           | 269,816                | 56,745                 | 213,071                     |
| Bank Fees  | -                 | -                      | 39                     | (39)                        |
| <b>Total Administration</b>                                  | <b>316,500</b>    | <b>290,125</b>         | <b>56,784</b>          | <b>233,341</b>              |
| <b>TOTAL EXPENDITURES</b>                                    | <b>316,500</b>    | <b>290,125</b>         | <b>56,784</b>          | <b>233,341</b>              |
| Excess (deficiency) of revenues<br>Over (under) expenditures | -                 | 26,375                 | 270,772                | 244,397                     |
| Net change in fund balance                                   | \$ -              | \$ 26,375              | \$ 270,772             | \$ 244,397                  |
| <b>FUND BALANCE, BEGINNING (OCT 1, 2017)</b>                 | <b>-</b>          | <b>-</b>               | <b>-</b>               |                             |
| <b>FUND BALANCE, ENDING</b>                                  | <b>\$ -</b>       | <b>\$ 26,375</b>       | <b>\$ 270,772</b>      |                             |

# **City of Westlake**

## **Supporting Schedules**

**August 31, 2018**

Cash and Investment Report

*August 31, 2018*

|                     |
|---------------------|
| <b>GENERAL FUND</b> |
|---------------------|

| <u>Account Name</u>          | <u>Bank Name</u> | <u>Investment Type</u> | <u>Maturity</u> | <u>Yield</u>    | <u>Balance</u>   |
|------------------------------|------------------|------------------------|-----------------|-----------------|------------------|
| Checking Account - Operating | BankUnited       | Checking Account       | n/a             | n/a             | \$567,528        |
| Money Market                 | BankUnited       | MMA                    | n/a             | 1.00%           | \$87,209         |
|                              |                  |                        |                 | <b>Subtotal</b> | <u>\$654,737</u> |

|                             |
|-----------------------------|
| <b>SPECIAL REVENUE FUND</b> |
|-----------------------------|

|              |            |     |     |                 |                         |
|--------------|------------|-----|-----|-----------------|-------------------------|
| Money Market | BankUnited | MMA | n/a | 1.00%           | \$280,772               |
|              |            |     |     | <b>Subtotal</b> | <u>\$280,772</u>        |
|              |            |     |     | <b>Total</b>    | <u><u>\$935,510</u></u> |



**City of Westlake**

Bank Reconciliation

Bank Account No. 0300 Bank United - GF  
 Statement No. 08-18B  
 Statement Date 8/31/2018

|                      |            |                      |            |
|----------------------|------------|----------------------|------------|
| G/L Balance (LCY)    | 567,527.99 | Statement Balance    | 618,771.34 |
| G/L Balance          | 567,527.99 | Outstanding Deposits | 0.00       |
| Positive Adjustments | 0.00       |                      |            |
|                      |            | Subtotal             | 618,771.34 |
| Subtotal             | 567,527.99 | Outstanding Checks   | 51,243.35  |
| Negative Adjustments | 0.00       | Differences          | 0.00       |
|                      |            |                      |            |
| Ending G/L Balance   | 567,527.99 | Ending Balance       | 567,527.99 |
| Difference           | 0.00       |                      |            |

| Posting Date                         | Document Type | Document No. | Description                | Amount           | Cleared Amount | Difference       |
|--------------------------------------|---------------|--------------|----------------------------|------------------|----------------|------------------|
| <b>Outstanding Checks</b>            |               |              |                            |                  |                |                  |
| 7/4/2018                             | Payment       | DD130        | Payment of Invoice 000986  | 597.26           | 0.00           | 597.26           |
| 7/6/2018                             | Payment       | 7505         | SISCA CONSTRUCTION SVC LLC | 150.00           | 0.00           | 150.00           |
| 7/16/2018                            | Payment       | 7510         | CROWN CASTLE-STA PROPERTY  | 202.88           | 0.00           | 202.88           |
| 8/6/2018                             | Payment       | 7525         | CABLENET SOLUTIONS, INC    | 89.00            | 0.00           | 89.00            |
| 8/20/2018                            | Payment       | 7539         | HIRE ME HANDY, INC         | 450.00           | 0.00           | 450.00           |
| 8/27/2018                            | Payment       | 7540         | INFRAMARK, LLC             | 31,579.00        | 0.00           | 31,579.00        |
| 8/27/2018                            | Payment       | 7542         | NZ CONSULTANTS, INC        | 17,450.00        | 0.00           | 17,450.00        |
| 8/27/2018                            | Payment       | 7543         | FED EX                     | 76.36            | 0.00           | 76.36            |
| 8/31/2018                            | Payment       | 7546         | T-MOBILE USA, INC          | 217.79           | 0.00           | 217.79           |
| 8/31/2018                            | Payment       | 7547         | OFFICE DEPOT               | 331.06           | 0.00           | 331.06           |
| 8/31/2018                            | Payment       | DD147        | Payment of Invoice 001120  | 100.00           | 0.00           | 100.00           |
| <b>Total Outstanding Checks.....</b> |               |              |                            | <b>51,243.35</b> |                | <b>51,243.35</b> |

## **City of Westlake**

**Check register**

**August 1-31, 2018**

**CITY OF WESTLAKE**

**Payment Register by Fund  
For the Period from 8/1/2018 to 8/31/2018  
(Sorted by Check / ACH No.)**

| Fund No.                  | Check / ACH No. | Date     | Payee                                | Invoice No.          | Payment Description            | Invoice / GL Description                 | G/L Account # | Amount Paid |
|---------------------------|-----------------|----------|--------------------------------------|----------------------|--------------------------------|--|---------------|-------------|
| <b>GENERAL FUND - 001</b> |                 |          |                                      |                      |                                |  |               |             |
| 001                       | 7520            | 08/02/18 | INFRAMARK, LLC                       | 32360                | MANAGEMENT FEES 7/18           | Management Services                      | 531093-51301  | \$31,196.83 |
| 001                       | 7520            | 08/02/18 | INFRAMARK, LLC                       | 32360                | MANAGEMENT FEES 7/18           | Postage                                  | 541010-51301  | \$11.75     |
| 001                       | 7520            | 08/02/18 | INFRAMARK, LLC                       | 32360                | MANAGEMENT FEES 7/18           | ProfServ-Web Site Maintenance            | 531094-51301  | \$366.67    |
| 001                       | 7521            | 08/06/18 | T-MOBILE USA, INC.                   | 63851-072018         | 955763851 SERVICE FOR 7/18     | Communication - Telephone                | 541003-51301  | \$218.63    |
| 001                       | 7522            | 08/06/18 | MARK L. DUBOIS                       | 18186                | CONSULTING FOR 7/18            | ProfServ-Consultants                     | 531075-51301  | \$650.00    |
| 001                       | 7523            | 08/06/18 | FLORIDA TECHNICAL CONSULTANTS        | 477                  | SERVICE FOR 6/25 THRU 7/27/18  | General Government                       | 549109-51301  | \$4,555.00  |
| 001                       | 7524            | 08/06/18 | DAVID DELGADO                        | 2614                 | MISC LABOR FOR 7/13/18         | Communication - Telephone                | 541003-51301  | \$897.50    |
| 001                       | 7525            | 08/06/18 | CABLENET SOLUTIONS, INC              | 072618-REFUND        | DOUBLE PAYMENT PAID W PERMIT   | Building Permits                         | 322000        | \$89.00     |
| 001                       | 7528            | 08/14/18 | NZ CONSULTANTS, INC.                 | WES-21               | PROF PLANNING & ZONING 6/18    | ProfServ-Planning/Zoning Board           | 531032-51501  | \$14,125.00 |
| 001                       | 7529            | 08/14/18 | FED EX                               | 6-261-22680          | SERVICE FOR 7/25/18            | Postage and Freight                      | 541006-51301  | \$40.54     |
| 001                       | 7530            | 08/14/18 | SOLID WASTE AUTHORITY                | SWA-073118           | SOLID WASTE AUTHORITY FEE 7/18 | Solid Waste fees                         | 202130        | \$3,357.90  |
| 001                       | 7531            | 08/20/18 | LAW OFFICES OF PAM E. BOOKER, ESQ    | 126                  | 8/18 LEGAL SERVICE             | ProfServ-Legal Services                  | 531023-51401  | \$24,282.25 |
| 001                       | 7532            | 08/20/18 | NOVA ENGINEERING AND                 | 0169370              | PROF SERVICE 7/1-7/28/18       | ProfServ-Building Permits                | 531091-51501  | \$52,800.00 |
| 001                       | 7533            | 08/20/18 | CMG-PB REMITTANCE ADDRESS            | 35857-080318         | PUBLIC HEARING NOTICE 8/3/18   | Legal Advertising                        | 548002-51301  | \$700.00    |
| 001                       | 7534            | 08/20/18 | OFFICE DEPOT                         | 174510232002         | FILE FOLDERS                   | Office Supplies                          | 551002-51301  | \$25.19     |
| 001                       | 7534            | 08/20/18 | OFFICE DEPOT                         | 174509644001         | MISC OFFICE SUPPLIES           | Office Supplies                          | 551002-51301  | \$68.39     |
| 001                       | 7534            | 08/20/18 | OFFICE DEPOT                         | 174510235001         | MAGNETIC CLIPS                 | Office Supplies                          | 551002-51301  | \$9.89      |
| 001                       | 7534            | 08/20/18 | OFFICE DEPOT                         | 174510233001         | MISC OFFICE SUPPLIES           | Office Supplies                          | 551002-51301  | \$114.09    |
| 001                       | 7534            | 08/20/18 | OFFICE DEPOT                         | 174510234001         | OFFICE SUPPLIES                | Office Supplies                          | 551002-51301  | \$9.49      |
| 001                       | 7534            | 08/20/18 | OFFICE DEPOT                         | 17492559001          | DESK CALENDAR                  | Office Supplies                          | 551002-51301  | \$10.49     |
| 001                       | 7535            | 08/20/18 | PBC SHERIFF'S OFFICE                 | 60681                | SECURITY 7/9/18 PUBLIC MEETING | Contracts-Sheriff                        | 534100-52901  | \$212.00    |
| 001                       | 7535            | 08/20/18 | PBC SHERIFF'S OFFICE                 | 60682                | SECURITY 7/4/18 7/1-7/31/18    | Contracts-Sheriff                        | 534100-52901  | \$6,175.00  |
| 001                       | 7536            | 08/20/18 | MARK L. DUBOIS                       | 18188                | SERVICES 7/30-8/9              | ProfServ-Consultants                     | 531075-51301  | \$725.00    |
| 001                       | 7537            | 08/20/18 | MINTO COMMUNITIES, LLC               | 081518-REFUND-INSPEC | REFUND RE INSPECTION FEES      | Misc-Contingency                         | 549900-51301  | \$250.00    |
| 001                       | 7538            | 08/20/18 | BERGER, TOOMBS, ELAM, GAINES & FRANK | 02117265             | FY17 FINANCIAL STATEMENT AUDIT | Auditing Services                        | 532002-51301  | \$3,085.00  |
| 001                       | 7539            | 08/20/18 | HIRE ME HANDY, INC.                  | 081018-HIRE ME       | OVER PAYMENT OF BUILDING PERMI | Building Permits                         | 322000        | \$450.00    |
| 001                       | 7540            | 08/27/18 | INFRAMARK, LLC                       | 33329                | 8/18 MANAGEMENT FEES           | Misc-Contingency                         | 549900-51301  | \$3.75      |
| 001                       | 7540            | 08/27/18 | INFRAMARK, LLC                       | 33329                | 8/18 MANAGEMENT FEES           | Management Services                      | 531093-51301  | \$31,196.83 |
| 001                       | 7540            | 08/27/18 | INFRAMARK, LLC                       | 33329                | 8/18 MANAGEMENT FEES           | Postage and Freight                      | 541006-51301  | \$11.75     |
| 001                       | 7540            | 08/27/18 | INFRAMARK, LLC                       | 33329                | 8/18 MANAGEMENT FEES           | ProfServ-Web Site Maintenance            | 531094-51301  | \$366.67    |
| 001                       | 7541            | 08/27/18 | CHEN MOORE & ASSOCIATES, INC.        | 0000135604           | PROF SERVICE 7/18              | ProfServ-Engineering                     | 531013-51501  | \$15,797.88 |
| 001                       | 7542            | 08/27/18 | NZ CONSULTANTS, INC.                 | WES-22               | PROF PLANNING & ZONING SERVICE | ProfServ-Planning/Zoning Board           | 531032-51501  | \$17,450.00 |
| 001                       | 7543            | 08/27/18 | FED EX                               | 6-275-17009          | SERVICE FOR 8/6 THRU 8/7/18    | Postage and Freight                      | 541006-51301  | \$47.68     |
| 001                       | 7543            | 08/27/18 | FED EX                               | 6-282-22179          | SERVICE FOR 8/14/18            | Postage and Freight                      | 541006-51301  | \$28.68     |
| 001                       | 7544            | 08/27/18 | FLORIDA TECHNICAL CONSULTANTS        | 487                  | SERVICE FOR 8/18               | General Government                       | 549109-51301  | \$19,915.00 |
| 001                       | 7545            | 08/27/18 | FPL                                  | 081518-89127         | 61367-89127 8/18 Strights      | Misc-Contingency                         | 549900-51301  | \$34.59     |
| 001                       | 7546            | 08/31/18 | T-MOBILE USA, INC.                   | 63851-082118         | SERVICE FOR 7/21-8/20/18       | Communication - Telephone                | 541003-51301  | \$217.79    |
| 001                       | 7547            | 08/31/18 | OFFICE DEPOT                         | 191589159001         | MISC OFFICE SUPPLIES           | Office Supplies                          | 551002-51301  | \$310.31    |
| 001                       | 7547            | 08/31/18 | OFFICE DEPOT                         | 191639482001         | 2 HOLE PUNCH                   | Office Supplies                          | 551002-51301  | \$6.81      |
| 001                       | 7547            | 08/31/18 | OFFICE DEPOT                         | 191639481001         | USB,TWIST TURN,16GB            | Office Supplies                          | 551002-51301  | \$13.94     |
| 001                       | DD137           | 08/04/18 | CARD SERVICES CENTER                 | 071018-0935          | PURCHASES FOR 6/14-7/3/18      | POSTAL CENTER STAMPS                     | 541006-51301  | \$54.50     |
| 001                       | DD137           | 08/04/18 | CARD SERVICES CENTER                 | 071018-0935          | PURCHASES FOR 6/14-7/3/18      | SPONSORSHIP-YOUTH EXPLORATION LEADERSHIP | 549900-51301  | \$250.00    |

**CITY OF WESTLAKE**

**Payment Register by Fund  
For the Period from 8/1/2018 to 8/31/2018  
(Sorted by Check / ACH No.)**

| Fund No. | Check / ACH No. | Date     | Payee                | Invoice No.  | Payment Description             | Invoice / GL Description | G/L Account #     | Amount Paid         |
|----------|-----------------|----------|----------------------|--------------|---------------------------------|--------------------------|-------------------|---------------------|
| 001      | DD137           | 08/04/18 | CARD SERVICES CENTER | 071018-0935  | PURCHASES FOR 6/14-7/3/18       | AMAZON PRIME MEMBERSHIP  | 554020-51301      | \$13.24             |
| 001      | DD137           | 08/04/18 | CARD SERVICES CENTER | 071018-0935  | PURCHASES FOR 6/14-7/3/18       | PUBLIX CHEESECK ICE BOX  | 551002-51301      | \$8.99              |
| 001      | DD137           | 08/04/18 | CARD SERVICES CENTER | 071018-0935  | PURCHASES FOR 6/14-7/3/18       | misc refunds             | 549900-51301      | (\$117.98)          |
| 001      | DD147           | 08/31/18 | FPL                  | 082818-89127 | 89127 DEPOSIT-STRT LGHTS        | Prepaid Items            | 155000            | \$100.00            |
| 001      | DD138           | 08/13/18 | KARA S. CRUMP        | PAYROLL      | August 13, 2018 Payroll Posting |                          |                   | \$2,784.77          |
| 001      | DD139           | 08/13/18 | KATRINA L. LONG      | PAYROLL      | August 13, 2018 Payroll Posting |                          |                   | \$2,784.77          |
| 001      | DD140           | 08/13/18 | ROGER B MANNING      | PAYROLL      | August 13, 2018 Payroll Posting |                          |                   | \$2,826.27          |
| 001      | DD141           | 08/13/18 | JOHN A. STANAVITCH   | PAYROLL      | August 13, 2018 Payroll Posting |                          |                   | \$2,867.77          |
| 001      | 7527            | 08/13/18 | PHILLIP D EVERETT    | PAYROLL      | August 13, 2018 Payroll Posting |                          |                   | \$2,909.27          |
|          |                 |          |                      |              |                                 |                          | <b>Fund Total</b> | <b>\$244,308.89</b> |

|                          |                     |
|--------------------------|---------------------|
| <b>Total Checks Paid</b> | <b>\$244,308.89</b> |
|--------------------------|---------------------|

## **Seventh Order of Business**



# Berger, Toombs, Elam, Gaines & Frank

Certified Public Accountants PL

600 Citrus Avenue  
Suite 200  
Fort Pierce, Florida 34950

772/461-6120 // 461-1155  
FAX: 772/468-9278

August 28, 2018

City of Westlake  
c/o Inframark Infrastructure Management Services  
210 North University Drive, Suite 702  
Coral Springs, FL 33071

## **The Objective and Scope of the Audit of the Financial Statements**

You have requested that we audit the financial statements of City of Westlake, which comprise governmental activities, a discretely presented component unit, each major fund and the budgetary comparison for the General Fund as of and for the year ended September 30, 2018 which collectively comprise the basic financial statements. We are pleased to confirm our acceptance and our understanding of this audit engagement by means of this letter for the year ending September 30, 2018 and thereafter for two annual renewals if mutually agreed by City of Westlake and Berger, Toombs, Elam, Gaines, & Frank, Certified Public Accountants, PL.

Our audit will be conducted with the objective of expressing an opinion on the financial statements.

## **The Responsibility of the Auditor**

We will conduct the audit in accordance with auditing standards generally accepted in the United States of America and "Government Auditing Standards" issued by the Comptroller General of the United States. Those standards require that we plan and perform the audit to obtain reasonable assurance about whether the financial statements are free of material misstatement. An audit involves performing procedures to obtain audit evidence about the amounts and disclosures in the financial statements. The procedures selected depend on the auditor's judgment, including the assessment of the risks of material misstatement of the financial statements, whether due to fraud or error. An audit also includes evaluating the appropriateness of accounting policies used and the reasonableness of significant accounting estimates made by management, as well as evaluating the overall presentation of the financial statements.

Because of the inherent limitations of an audit, together with the inherent limitations of internal control, an unavoidable risk that some material misstatements may not be detected exists, even though the audit is properly planned and performed in accordance with generally accepted auditing standards. Also, an audit is not designed to detect errors or fraud that are immaterial to the financial statements. The determination of abuse is subjective; therefore, Government Auditing Standards do not expect us to provide reasonable assurance of detecting abuse.

Fort Pierce / Stuart

City of Westlake  
August 28, 2018  
Page 2

In making our risk assessments, we consider internal control relevant to City of Westlake's preparation and fair presentation of the financial statements in order to design audit procedures that are appropriate in the circumstances but not for the purpose of expressing an opinion on the effectiveness of the entity's internal control. However, we will communicate to you in writing concerning any significant deficiencies or material weaknesses in internal control relevant to the audit of the financial statements that we have identified during the audit.

We will also communicate to the Board any fraud involving senior management and fraud that causes a material misstatement of the financial statements that becomes known to us during the audit, and any instances of noncompliance with laws and regulations that we become aware of during the audit.

The funds that you have told us are maintained by City of Westlake and that are to be included as part of our audit are listed below:

1. General Fund

City of Westlake  
August 28, 2018  
Page 3

### **The Responsibilities of Management and Identification of the Applicable Financial Reporting Framework**

Our audit will be conducted on the basis that management acknowledges and understands that it has responsibility:

1. For the preparation and fair presentations of the financial statements in accordance with accounting principles generally accepted in the United States of America;
2. To evaluate subsequent events through the date the financial statements are issued or available to be issued, and to disclose the date through which subsequent events were evaluated in the financial statements. Management also agrees that it will not evaluate subsequent events earlier than the date of the management representation letter referred to below;
3. For the design, implementation, and maintenance of internal control relevant to the preparation and fair presentation of financial statements that are free from material misstatement, whether due to fraud or error;
4. For establishing and maintaining effective internal control of financial reporting and for informing us of all significant deficiencies and material weaknesses in the design or operation of such controls of which it has knowledge; and
5. To provide us with:
  - a. Access to all information of which management is aware that is relevant to the preparation and fair presentation of the financial statements such as records, documentation and other matters;
  - b. Additional information that we may request from management for the purpose of the audit; and
  - c. Unrestricted access to persons within the entity from whom we determine it necessary to obtain audit evidence.



City of Westlake  
August 28, 2018  
Page 4

Management is responsible for identifying and ensuring that City of Westlake complies with the laws and regulations applicable to its activities, and for informing us about all known material violations of such laws or regulations. In addition, management is responsible for the design and implementation of programs and controls to prevent and detect fraud or abuse, and for informing us about all known or suspected fraud or abuse affecting the entity involving management, employees who have significant roles in internal control, and others where the fraud or abuse could have a material effect on the financial statements or compliance. Management is also responsible for informing us of its knowledge of any allegations of fraud or abuse, or, suspected fraud or abuse affecting the entity received in communications from employees, former employees, analysts, regulators, short sellers, or others.

The Board is responsible for informing us of its views about the risks of fraud or abuse within the entity, and its knowledge of any fraud or abuse, or, suspected fraud or abuse affecting the entity.

City of Westlake agrees that it will not associate us with any public or private securities offering without first obtaining our consent. Therefore, City of Westlake agrees to contact us before it includes our reports or otherwise makes reference to us, in any public or private securities offering.

Because Berger, Toombs, Elam, Gaines & Frank will rely on City of Westlake and its management and Board of Supervisors to discharge the foregoing responsibilities, City of Westlake holds harmless and releases Berger, Toombs, Elam, Gaines & Frank, its partners, and employees from all claims, liabilities, losses and costs arising in circumstances where there has been a known misrepresentation by a member of City of Westlake's management, which has caused, in any respect, Berger, Toombs, Elam, Gaines & Frank's breach of contract or negligence. This provision shall survive the termination of this arrangement for services.

### **City of Westlake's Records and Assistance**

If circumstances arise relating to the condition of the City of Westlake's records, the availability of appropriate audit evidence, or indications of a significant risk of material misstatement of the financial statements, because of error, fraudulent financial reporting, or misappropriation of assets, which, in our professional judgment, prevent us from completing the audit or forming an opinion, we retain the unilateral right to take any course of action permitted by professional standards, including: declining to express an opinion, issuing a report, or withdrawing from engagement.

During the course of our engagement, we may accumulate records containing data that should be reflected in the City of Westlake's books and records. The District will determine that all such data, if necessary, will be so reflected. Accordingly, the District will not expect us to maintain copies of such records in our possession.

City of Westlake  
August 28, 2018  
Page 5

### **Other Relevant Information**

In accordance with Government Auditing Standards, a copy of our most recent peer review report has been provided to you, for your information.

### **Fees, Costs, and Access to Workpapers**

Our fees for the audit and accounting services described above are based upon the value of the services performed and the time required by the individuals assigned to the engagement, plus direct expenses. Invoices for fees will be submitted in sufficient detail to demonstrate compliance with the terms of this engagement. Billings are due upon submission. Our fee for the services described in this letter for the year ending September 30, 2018, will not exceed \$3,225, unless the scope of the engagement is changed, the assistance which City of Westlake has agreed to furnish is not provided, or unexpected conditions are encountered, in which case, we will discuss the situation with you before proceeding. All other provisions of this letter will survive any fee adjustment. The two annual renewals must be mutually agreed and approved by the Board of Supervisors.

In the event we are requested or authorized by City of Westlake or are required by government regulation, subpoena, or other legal process to produce our documents or our personnel as witnesses with respect to our engagement for City of Westlake, City of Westlake will, so long as we are not a party to the proceeding in which the information is sought, reimburse us for our professional time and expenses, as well as the fees and expenses of our counsel, incurred in responding to such requests.

The documentation for this engagement is the property of Berger, Toombs, Elam, Gaines, & Frank. However, you acknowledge and grant your assent that representatives of the cognizant or oversight agency or their designee, other government audit staffs, and the U.S. Government Accountability Office shall have access to the audit documentation upon their request and that we shall maintain the audit documentation for a period of at least three years after the date of the report, or for a longer period if we are requested to do so by the cognizant or oversight agency. Access to requested documentation will be provided under the supervision of Berger, Toombs, Elam, Gaines, & Frank audit personnel and at a location designated by our Firm.

City of Westlake  
August 28, 2018  
Page 6

**Reporting**

We will issue a written report upon completion of our audit of City of Westlake’s financial statements. Our report will be addressed to the Board of City of Westlake. We cannot provide assurance that an unmodified opinion will be expressed. Circumstances may arise in which it is necessary for us to modify our opinion, add an emphasis-of-matter or other-matter paragraph(s), or withdraw from the engagement.

In addition to our report on City of Westlake’s financial statements, we will also issue the following types of reports:

- Reports on internal control and compliance with laws, regulations, and the provisions of contracts or grant agreements. We will report on any internal control findings and/or noncompliance which could have a material effect on the financial statements.

This letter constitutes the complete and exclusive statement of agreement between Berger, Toombs, Elam, Gaines & Frank and City of Westlake, superseding all proposals, oral or written, and all other communication, with respect to the terms of the engagement between the parties.

Please sign and return the attached copy of this letter to indicate your acknowledgement of, and agreement with, the arrangements for our audit of the financial statements including our respective responsibilities.

*Berger Toombs Elam  
Gaines + Frank*  
Berger, Toombs, Elam, Gaines & Frank  
J. W. GAINES, CPA

Confirmed on behalf of the addressee:

---



---



---



Judson B. Baggett  
MBA, CPA, CVA, Partner  
Marci Reutimann  
CPA, Partner

6815 Dairy Road  
Zephyrhills, FL 33542  
(813) 788-2155  
(813) 782-8606

## System Review Report

To the Directors

November 2, 2016

Berger, Toombs, Elam, Gaines & Frank, CPAs PL  
and the Peer Review Committee of the Florida Institute of Certified Public Accountants

We have reviewed the system of quality control for the accounting and auditing practice of Berger, Toombs, Elam, Gaines & Frank, CPAs PL (the firm), in effect for the year ended May 31, 2016. Our peer review was conducted in accordance with the Standards for Performing and Reporting on Peer Reviews established by the Peer Review Board of the American Institute of Certified Public Accountants. As a part of our peer review, we considered reviews by regulatory entities, if applicable, in determining the nature and extent of our procedures. The firm is responsible for designing a system of quality control and complying with it to provide the firm with reasonable assurance of performing and reporting in conformity with applicable professional standards in all material respects. Our responsibility is to express an opinion on the design of the system of quality control, and the firm's compliance therewith based on our review. The nature, objectives, scope, limitations of, and the procedures performed in a System Review are described in the standards at [www.aicpa.org/prsummary](http://www.aicpa.org/prsummary).

As required by the standards, engagements selected for review included engagements performed under *Government Auditing Standards and audits of employee benefit plans*.

In our opinion, the system of quality control for the accounting and auditing practice of Berger, Toombs, Elam, Gaines & Frank, CPAs PL in effect for the year ended May 31, 2016 has been suitably designed and complied with to provide the firm with reasonable assurance of performing and reporting in conformity with applicable professional standards in all material respects. Firms can receive a rating of *pass*, *pass with deficiency(ies)*, or *fail*. Berger, Toombs, Elam, Gaines & Frank, CPAs PL, has received a peer review rating of *pass*.

  
Baggett, Reutimann & Associates, CPAs, PA

(BERGER\_REPORT16)

**ADDENDUM TO ENGAGEMENT LETTER BETWEEN BERGER, TOOMBS,  
ELAM, GAINES AND FRANK AND CITY OF WESTLAKE  
(DATED AUGUST 28, 2018)**

**Public Records.** Auditor shall, pursuant to and in accordance with Section 119.0701, Florida Statutes, comply with the public records laws of the State of Florida, and specifically shall:

- a. Keep and maintain public records required by the District to perform the services or work set forth in this Agreement; and
- b. Upon the request of the District's custodian of public records, provide the District with a copy of the requested records or allow the records to be inspected or copied within a reasonable time at a cost that does not exceed the cost provided in Chapter 119, Florida Statutes, or as otherwise provided by law; and
- c. Ensure that public records that are exempt or confidential and exempt from public records disclosure requirements are not disclosed except as authorized by law for the duration of the contract term and following completion of the Agreement if the Auditor does not transfer the records to the District; and
- d. Upon completion of the Agreement, transfer, at no cost to the District, all public records in possession of the Auditor or keep and maintain public records required by the District to perform the service or work provided for in this Agreement. If the Auditor transfers all public records to the District upon completion of the Agreement, the Auditor shall destroy any duplicate public records that are exempt or confidential and exempt from public disclosure requirements. If the Auditor keeps and maintains public records upon completion of the Agreement, the Auditor shall meet all applicable requirements for retaining public records. All records stored electronically must be provided to the District, upon request from the District's custodian of public records, in a format that is compatible with the information technology systems of the District.

Auditor acknowledges that any requests to inspect or copy public records relating to this Agreement must be made directly to the District pursuant to Section 119.0701(3), Florida Statutes. If notified by the District of a public records request for records not in the possession of the District but in possession of the Auditor, the Auditor shall provide such records to the District or allow the records to be inspected or copied within a reasonable time. Auditor acknowledges that should Auditor fail to provide the public records to the District within a reasonable time, Auditor may be subject to penalties pursuant to Section 119.10, Florida Statutes.

**IF THE AUDITOR HAS QUESTIONS REGARDING THE APPLICATION OF CHAPTER 119, FLORIDA STATUTES, TO THE AUDITOR'S DUTY TO PROVIDE PUBLIC RECORDS RELATING TO THIS AGREEMENT/CONTRACT, THE AUDITOR MAY CONTACT THE CUSTODIAN OF PUBLIC RECORDS FOR THE DISTRICT AT:**

**INFRAMARK  
INFRASTRUCTURE MANAGEMENT SERVICES  
210 NORTH UNIVERSITY DRIVE, SUITE 702  
CORAL SPRINGS, FL 33071  
TELEPHONE: 954-603-0033  
EMAIL: \_\_\_\_\_**

**Auditor: J.W. Gaines**

**District: City of Westlake**

**By:** \_\_\_\_\_ 

**By:** \_\_\_\_\_

**Title: Director**

**Title:** \_\_\_\_\_

**Date: September 12, 2018**

**Date:** \_\_\_\_\_

## **Eighth Order of Business**

October 8, 2018 First Reading  
November 12, 2018 Second Reading

### **ORDINANCE 2019-1**

**AN ORDINANCE OF THE CITY COUNCIL FOR THE CITY OF WESTLAKE, FLORIDA, CREATING AN ARTICLE ENTITLED “FLOOD PREVENTION AND CONTROL”; TO ADOPT FLOOD HAZARD MAPS, TO DESIGNATE A FLOODPLAIN ADMINISTRATOR, TO ADOPT PROCEDURES AND CRITERIA FOR DEVELOPMENT IN FLOOD HAZARD AREAS, AND FOR OTHER PURPOSES; PROVIDING FOR APPLICABILITY AND PROVIDING AN EFFECTIVE DATE.**

---

**WHEREAS**, the Planning and Zoning Board reviewed the text addition at a public hearing held on October 8, 2018, and the Board made a recommendation to send the proposed changes to the City Council with a recommendation of approval; and

**WHEREAS**, pursuant to Florida Statute 163.3174(4)(c), the Planning and Zoning Board, sitting as the Local Planning Agency, has determined that the change is consistent with and furthers the goals, objectives and policies of the Comprehensive Plan; and

**WHEREAS**, the City Council for the City of Westlake adopts the findings in the Planning and Zoning Staff Report; and

**WHEREAS**, the City Council for the City of Westlake finds the ordinance is consistent with the Comprehensive Plan; and

**WHEREAS**, the Legislature of the State of Florida has, in Chapter 166 – Municipalities, Florida Statutes, conferred upon local governments the authority to adopt regulations designed to promote the public health, safety, and general welfare of its citizenry; and

**WHEREAS**, the Federal Emergency Management Agency has identified special flood hazard areas within the boundaries of the City of Westlake and such areas may be subject to periodic inundation which may result in loss of life and property, health and safety hazards, disruption of commerce and governmental services, extraordinary public expenditures for flood protection and relief, and impairment of the tax base, all of which adversely affect the public health, safety and general welfare; and

**WHEREAS**, the City of Westlake is applying for participation in the National Flood Insurance Program and the City Council for the City of Westlake desires to meet the requirements of Title 44 Code of Federal Regulations, Sections 59 and 60, necessary for such participation; and

**WHEREAS**, Chapter 553, Florida Statutes, was adopted by the Florida Legislature to provide a mechanism for the uniform adoption, updating, amendment, interpretation and enforcement of a state building code, called the Florida Building Code; and



**WHEREAS**, the City of Westlake City Council has determined that it is in the public interest to adopt the proposed floodplain management regulations that are coordinated with the Florida Building Code.

**NOW, THEREFORE, BE IT ORDAINED** by the City Council for the City of Westlake in that the following floodplain management regulations are hereby adopted.

**Section 1: Incorporation:** That the recitations set forth above are incorporated herein.

**Section 2: ARTICLE 10 FLOOD PREVENTION AND CONTROL**

**Section 10.1.1 General Provisions:**

**(A) Title:** These regulations shall be known as “Floodplain Management Regulations”, article of the Land Development Regulations (LDR) of the Code of Ordinances of the City of Westlake, Florida, shall read as follows:

**(B) Scope:** The provisions of the Floodplain Management Regulations shall apply to all development that is wholly within or partially within any flood hazard area, including but not limited to the subdivision of land; filling, grading, and other site improvements and utility installations; construction, alteration, remodeling, enlargement, improvement, replacement, repair, relocation or demolition of buildings, structures, and facilities that are exempt from the Florida Building Code; placement, installation, or replacement of manufactured homes and manufactured buildings; installation or replacement of tanks; placement of recreational vehicles; installation of swimming pools; and any other development. Where specified, these regulations apply outside of mapped flood hazard areas.

**(C) Intent:** The purposes of the Floodplain Management Regulations and the flood load and flood resistant construction requirements of the Florida Building Code are to establish minimum requirements to safeguard the public health, safety, and general welfare and to minimize public and private losses due to flooding through regulation of development in flood hazard areas to:

- (1) Minimize unnecessary disruption of commerce, access and public service during times of flooding;
- (2) Require the use of appropriate construction practices in order to prevent or minimize future flood damage;
- (3) Manage filling, grading, dredging, mining, paving, excavation, drilling operations, storage of equipment or materials, and other development which may increase flood damage or erosion potential;
- (4) Minimize damage to public and private facilities and utilities;
- (5) Help maintain a stable tax base by providing for the sound use and development of flood hazard areas;
- (6) Minimize the need for future expenditure of public funds for flood control projects and response

to and recovery from flood events; and

- (7) Meet the requirements of the National Flood Insurance Program for community participation as set forth in the Title 44 Code of Federal Regulations, Section 59.22.

**(D) Coordination with the Florida Building Code:** The Floodplain Management Regulations are intended to be administered and enforced in conjunction with the Florida Building Code. Where cited, ASCE 24 refers to the edition of the standard that is referenced by the Florida Building Code.

**(E) Warning:** The degree of flood protection required by the Floodplain Management Regulations and the Florida Building Code, as amended by this community, is considered the minimum reasonable for regulatory purposes and is based on scientific and engineering considerations. Larger floods can and will occur. Flood heights may be increased by man-made or natural causes. The Floodplain Management Regulations do not imply that land outside of mapped special flood hazard areas, or that uses permitted within such flood hazard areas, will be free from flooding or flood damage. The flood hazard areas and base flood elevations contained in the Flood Insurance Study and shown on Flood Insurance Rate Maps and the requirements of Title 44 Code of Federal Regulations, Sections 59 and 60 may be revised by the Federal Emergency Management Agency, requiring this community to revise these regulations to remain eligible for participation in the National Flood Insurance Program. No guaranty of vested use, existing use, or future use is implied or expressed by compliance with the Floodplain Management Regulations.

**(F) Disclaimer of Liability:** The Floodplain Management Regulations shall not create liability on the part of the City Council of the City of Westlake or by any officer or employee thereof for any flood damage that results from reliance on the Floodplain Management Regulations or any administrative decision lawfully made thereunder.

#### **Section 10.1.2 Applicability:**

**(A) General:** Where there is a conflict between a general requirement and a specific requirement, the specific requirement shall be applicable.

**(B) Areas to which the Floodplain Management Regulations Apply:** The Floodplain Management Regulations shall apply to all flood hazard areas within the City of Westlake, as established in LDR Section 10.1.2(C).

**(C) Basis for Establishing Flood Hazard Areas:** The Flood Insurance Study for Palm Beach County, Florida and Incorporated Areas dated October 5, 2017, and all subsequent amendments and revisions, and the accompanying Flood Insurance Rate Maps (FIRM), and all subsequent amendments and revisions to such maps, are adopted by reference as a part of the Floodplain Management Regulations and shall serve as the minimum basis for establishing flood hazard areas. Studies and maps that establish flood hazard areas are on file at the City of Westlake Building Division, 4001 Seminole Pratt Whitney Road, Westlake Florida, 33470.

**(D) Submission of Additional Data to Establish Flood Hazard Areas:** To establish flood hazard areas and base flood elevations, pursuant to LDR Section 10.1.5 the Floodplain Administrator may require submission of additional data. Where field surveyed topography prepared by a Florida licensed

professional surveyor or digital topography accepted by the community indicates that ground elevations:

- (1) Are below the closest applicable base flood elevation, even in areas not delineated as a special flood hazard area on a FIRM, the area shall be considered as flood hazard area and subject to the requirements of the Floodplain Management Regulations and, as applicable, the requirements of the Florida Building Code.
- (2) Are above the closest applicable base flood elevation, the area shall be regulated as special flood hazard area unless the applicant obtains a Letter of Map Change that removes the area from the special flood hazard area.

**(E) Other Laws:** The provisions of the Floodplain Management Regulations shall not be deemed to nullify any provisions of local, state or federal law.

**(F) Abrogation and Greater Restrictions:** The Floodplain Management Regulations supersede any LDR Section in effect for management of development in flood hazard areas. However, it is not intended to repeal or abrogate any existing ordinances including but not limited to land development regulations, zoning ordinances, stormwater management regulations, or the Florida Building Code. In the event of a conflict between the Floodplain Management Regulations and any other ordinance, the more restrictive shall govern. The Floodplain Management Regulations shall not impair any deed restriction, covenant or easement, but any land that is subject to such interests shall also be governed by the Floodplain Management Regulations.

**(G) Interpretation:** In the interpretation and application of the Floodplain Management Regulations, all provisions shall be:

- (1) Considered as minimum requirements
- (2) Liberally construed in favor of the governing body; and
- (3) Deemed neither to limit nor repeal any other powers granted under state statutes.

#### **Section 10.1.3 Duties and Powers of the Floodplain Administrator:**

**(A) Designation:** The Building Official is designated as the Floodplain Administrator. The Floodplain Administrator may delegate performance of certain duties to other employees.

**(B) General:** The Floodplain Administrator is authorized and directed to administer and enforce the provisions of the Floodplain Management Regulations. The Floodplain Administrator shall have the authority to render interpretations of the Floodplain Management Regulations consistent with the intent and purpose of the Floodplain Management Regulations and may establish policies and procedures in order to clarify the application of its provisions. Such interpretations, policies, and procedures shall not have the effect of waiving requirements specifically provided in the Floodplain Management Regulations without the granting of a variance pursuant to LDR Section 10.1.7.

**(C) Applications and Permits:** The Floodplain Administrator, in coordination with other pertinent offices of the community, shall:

- (1) Review applications and plans to determine whether proposed new development will be located in flood hazard areas;
- (2) Review applications for modification of any existing development in flood hazard areas for

- compliance with the requirements of the Floodplain Management Regulations;
- (3) Interpret flood hazard area boundaries where such interpretation is necessary to determine the exact location of boundaries; a person contesting the determination shall have the opportunity to appeal the interpretation;
  - (4) Provide available flood elevation and flood hazard information;
  - (5) Determine whether additional flood hazard data shall be obtained from other sources or shall be developed by an applicant;
  - (6) Review applications to determine whether proposed development will be reasonably safe from flooding;
  - (7) Issue floodplain development permits or approvals for development other than buildings and structures that are subject to the Florida Building Code, including buildings, structures and facilities exempt from the Florida Building Code, when compliance with the Floodplain Management Regulations is demonstrated, or disapprove the same in the event of noncompliance; and
  - (8) Coordinate with and provide comments to the Building Official to assure that applications, plan reviews, and inspections for buildings and structures in flood hazard areas comply with the applicable provisions of the Floodplain Management Regulations.

(D) **Substantial Improvement and Substantial Damage Determinations:** For applications for building permits to improve buildings and structures, including alterations, movement, enlargement, replacement, repair, change of occupancy, additions, rehabilitations, renovations, substantial improvements, repairs of substantial damage, and any other improvement of or work on such buildings and structures, the Floodplain Administrator, in coordination with the Building Official, shall:

- (1) Estimate the market value, or require the applicant to obtain an appraisal of the market value prepared by a qualified independent appraiser, of the building or structure before the start of construction of the proposed work; in the case of repair, the market value of the building or structure shall be the market value before the damage occurred and before any repairs are made;
- (2) Compare the cost to perform the improvement, the cost to repair a damaged building to its pre-damaged condition, or the combined costs of improvements and repairs, if applicable, to the market value of the building or structure;
- (3) Determine and document whether the proposed work constitutes substantial improvement or repair of substantial damage; and
- (4) Notify the applicant if it is determined that the work constitutes substantial improvement or repair of substantial damage and that compliance with the flood resistant construction requirements of the Florida Building Code and the Floodplain Management Regulations is required.

(E) **Modifications of the Strict Application of the Requirements of the Florida Building Code:** The Floodplain Administrator shall review requests submitted to the Building Official that seek approval to modify the strict application of the flood load and flood resistant construction requirements of the Florida Building Code to determine whether such requests require the granting of a variance pursuant to

LDR Section 10.1.7.

(F) **Notices and Orders:** The Floodplain Administrator shall coordinate with appropriate local agencies for the issuance of all necessary notices or orders to ensure compliance with the Floodplain Management Regulations.

(G) **Inspections:** The Floodplain Administrator shall make the required inspections as specified in LDR Section 10.1.6 for development that is not subject to the Florida Building Code, including buildings, structures and facilities exempt from the Florida Building Code. The Floodplain Administrator shall inspect flood hazard areas to determine if development is undertaken without issuance of a permit.

(H) **Other Duties of the Floodplain Administrator:** The Floodplain Administrator shall have other duties, including but not limited to:

- (1) Establish, in coordination with the Building Official, procedures for administering and documenting determinations of substantial improvement and substantial damage made pursuant to LDR Section 10,1.3(4).
- (2) Require applicants who submit hydrologic and hydraulic engineering analyses to support permit applications to submit to FEMA the data and information necessary to maintain the Flood Insurance Rate Maps if the analyses propose to change base flood elevations or flood hazard area boundaries; such submissions shall be made within 6 months of such data becoming available;
- (3) Review required design certifications and documentation of elevations specified by the Floodplain Management Regulations and the Florida Building Code to determine that such certifications and documentations are complete; and
- (4) Notify the Federal Emergency Management Agency when the corporate boundaries of the City of Westlake are modified.

(I) **Floodplain Management Records:** Regardless of any limitation on the period required for retention of public records, the Floodplain Administrator shall maintain and permanently keep and make available for public inspection all records that are necessary for the administration of the Floodplain Management Regulations and the flood resistant construction requirements of the Florida Building Code, including Flood Insurance Rate Maps; Letters of Map Change; records of issuance of permits and denial of permits; determinations of whether proposed work constitutes substantial improvement or repair of substantial damage; required design certifications and documentation of elevations specified by the Florida Building Code and the Floodplain Management Regulations; documentation related to appeals and variances, including justification for issuance or denial; and records of enforcement actions taken pursuant to the Floodplain Management Regulations and the flood resistant construction requirements of the Florida Building Code. These records shall be available for public inspection at the City of Westlake Building Department, 4001 Seminole Pratt Whitney Road, Westlake, Florida 33470.

#### **Section 10.1.4 Permits.**

(A) **Permits Required:** Any owner or owner's authorized agent (hereinafter "applicant") who intends to undertake any development activity within the scope of the Floodplain Management Regulations, including buildings, structures and facilities exempt from the Florida Building Code, which

is wholly within or partially within any flood hazard area shall first make application to the Floodplain Administrator, and shall obtain the required permit(s) and approval(s). No such permit or approval shall be issued until compliance with the requirements of the Floodplain Management Regulations and all other applicable codes and regulations has been satisfied.

(B) **Floodplain Development Permits or Approvals:** Floodplain development permits or approvals shall be issued pursuant to the Floodplain Management Regulations for any development activities not subject to the requirements of the Florida Building Code, including buildings, structures and facilities exempt from the Florida Building Code. Depending on the nature and extent of proposed development that includes a building or structure, the Floodplain Administrator may determine that a floodplain development permit or approval is required in addition to a building permit.

(C) **Buildings, Structures and Facilities Exempt from the Florida Building Code:** Pursuant to the requirements of federal regulation for participation in the National Flood Insurance Program (44 C.F.R. Sections 59 and 60), floodplain development permits or approvals shall be required for the following buildings, structures and facilities that are exempt from the Florida Building Code and any further exemptions provided by law, which are subject to the requirements of the Floodplain Management Regulations:

- (1) Railroads and ancillary facilities associated with the railroad.
- (2) Nonresidential farm buildings on farms, as provided in section 604.50, F.S.
- (3) Temporary buildings or sheds used exclusively for construction purposes.
- (4) Mobile or modular structures used as temporary offices.
- (5) Those structures or facilities of electric utilities, as defined in section 366.02, F.S., which are directly involved in the generation, transmission, or distribution of electricity.
- (6) Chickees constructed by the Miccosukee Tribe of Indians of Florida or the Seminole Tribe of Florida. As used in this paragraph, the term “chickee” means an open-sided wooden hut that has a thatched roof of palm or palmetto or other traditional materials, and that does not incorporate any electrical, plumbing, or other non-wood features.
- (7) Family mausoleums not exceeding 250 square feet in area which are prefabricated and assembled on site or preassembled and delivered on site and have walls, roofs, and a floor constructed of granite, marble, or reinforced concrete.
- (8) Temporary housing provided by the Department of Corrections to any prisoner in the state correctional system.
- (9) Structures identified in section 553.73(10) (k), F.S., are not exempt from the Florida Building Code if such structures are located in flood hazard areas established on Flood Insurance Rate Maps.

(D) **Application for a Permit or Approval:** To obtain a floodplain development permit or approval the applicant shall first file an application in writing on a form furnished by the community. The information provided shall:

- (1) Identify and describe the development to be covered by the permit or approval.

- (2) Describe the land on which the proposed development is to be conducted by legal description, street address or similar description that will readily identify and definitively locate the site.
- (3) Indicate the use and occupancy for which the proposed development is intended.
- (4) Be accompanied by a site plan or construction documents as specified in LDR Section 10.1.5.
- (5) State the valuation of the proposed work.
- (6) Be signed by the applicant or the applicant's authorized agent.
- (7) Give such other data and information as required by the Floodplain Administrator.

**(E) Validity of Permit or Approval:** The issuance of a floodplain development permit or approval pursuant to the Floodplain Management Regulations shall not be construed to be a permit for, or approval of, any violation of the Floodplain Management Regulations, the Florida Building Codes, or any other ordinance of this community. The issuance of permits based on submitted applications, construction documents, and information shall not prevent the Floodplain Administrator from requiring the correction of errors and omissions.

**(F) Expiration:** A floodplain development permit or approval shall become invalid unless the work authorized by such permit is commenced within 180 days after its issuance, or if the work authorized is suspended or abandoned for a period of 180 days after the work commences. Extensions for periods of not more than 180 days each shall be requested in writing and justifiable cause shall be demonstrated.

**(G) Suspension or Revocation:** The Floodplain Administrator is authorized to suspend or revoke a floodplain development permit or approval if the permit was issued in error, on the basis of incorrect, inaccurate or incomplete information, or in violation of the Floodplain Management Regulations or any other ordinance, regulation or requirement of this community.

**(H) Other Permits Required:** Floodplain development permits and building permits shall include a condition that all other applicable state or federal permits be obtained before commencement of the permitted development, including but not limited to the following:

- (1) The South Florida Water Management District; section 373.036, F.S.
- (2) Florida Department of Health for onsite sewage treatment and disposal systems; section 381.0065, F.S. and Chapter 64E-6, F.A.C.
- (3) Florida Department of Environmental Protection for activities subject to the Joint Coastal Permit; section 161.055, F.S.
- (4) Florida Department of Environmental Protection for activities that affect wetlands and alter surface water flows, in conjunction with the U.S. Army Corps of Engineers; Section 404 of the Clean Water Act.
- (5) Federal permits and approvals.

#### **Section 10.1.5 Site Plans and Construction Documents:**

**(A) Information for Development in Flood Hazard Areas:** The site plan or construction documents for any development subject to the requirements of the Floodplain Management Regulations shall be drawn to scale and shall include, as applicable to the proposed development:

- (1) Delineation of flood hazard areas boundaries and flood zone(s), base flood elevation(s), and

- ground elevations if necessary for review of the proposed development.
- (2) Where base flood elevations are not included on the FIRM or in the Flood Insurance Study, they shall be established in accordance with LDR Section 10.1.5(B)(2) or (3).
  - (3) Where the parcel on which the proposed development will take place will have more than 50 lots or is larger than 5 acres and the base flood elevations are not included on the FIRM or in the Flood Insurance Study, such elevations shall be established in LDR Section 10.1.5(B)(1).
  - (4) Location of the proposed activity and proposed structures, and locations of existing buildings and structures.
  - (5) Location, extent, amount, and proposed final grades of any filling, grading, or excavation.
  - (6) Where the placement of fill is proposed, the amount, type, and source of fill material; compaction specifications; a description of the intended purpose of the fill areas; and evidence that the proposed fill areas are the minimum necessary to achieve the intended purpose.

The Floodplain Administrator is authorized to waive the submission of site plans, construction documents, and other data that are required by the Floodplain Management Regulations but that are not required to be prepared by a registered design professional if it is found that the nature of the proposed development is such that the review of such submissions is not necessary to ascertain compliance with the Floodplain Management Regulations.

**(B) Information in Flood Hazard Areas Without Base Flood Elevations (Approximate Zone A):**

Where flood hazard areas are delineated on the FIRM and base flood elevation data have not been provided, the Floodplain Administrator shall:

- (1) Require the applicant to include base flood elevation data prepared in accordance with currently accepted engineering practices.
- (2) Obtain, review, and provide to applicants base flood elevation data available from a federal or state agency or other source or require the applicant to obtain and use base flood elevation data available from a federal or state agency or other source.
- (3) Where base flood elevation data are not available from another source, where the available data are deemed by the Floodplain Administrator to not reasonably reflect flooding conditions, or where the available data are known to be scientifically or technically incorrect or otherwise inadequate:
  - a. Require the applicant to include base flood elevation data prepared in accordance with currently accepted engineering practices; or
  - b. Specify that the base flood elevation is two (2) feet above the highest adjacent grade at the location of the development, provided there is no evidence indicating flood depths have been or may be greater than two (2) feet.
- (4) Where the base flood elevation data are to be used to support a Letter of Map Change from FEMA, advise the applicant that the analyses shall be prepared by a Florida licensed engineer in a format required by FEMA, and that it shall be the responsibility of the applicant to satisfy the submittal requirements and pay the processing fees.



(C) **Submission of Additional Data:** When additional hydrologic, hydraulic or other engineering data, studies, and additional analyses are submitted to support an application, the applicant has the right to seek a Letter of Map Change from FEMA to change the base flood elevations, change floodway boundaries, or change boundaries of flood hazard areas shown on FIRMs, and to submit such data to FEMA for such purposes. The analyses shall be prepared by a Florida licensed engineer in a format required by FEMA. Submittal requirements and processing fees shall be the responsibility of the applicant.

**Section 10.1.6 Inspections.**

(A) **General:** Development for which a floodplain development permit or approval is required shall be subject to inspection.

(B) **Development Other Than Buildings and Structures:** The Floodplain Administrator shall inspect all development to determine compliance with the requirements of the Floodplain Management Regulations and the conditions of issued floodplain development permits or approvals.

(C) **Buildings, Structures and Facilities Exempt from the Florida Building Code:** The Floodplain Administrator shall inspect buildings, structures and facilities exempt from the Florida Building Code to determine compliance with the requirements of the Floodplain Management Regulations and the conditions of issued floodplain development permits or approvals.

(D) **Buildings, Structures and Facilities Exempt from the Florida Building Code, Lowest Floor Inspection:** Upon placement of the lowest floor, including basement, and prior to further vertical construction, the owner of a building, structure or facility exempt from the Florida Building Code, or the owner's authorized agent, shall submit to the Floodplain Administrator:

- (1) If a design flood elevation was used to determine the required elevation of the lowest floor, the certification of elevation of the lowest floor prepared and sealed by a Florida licensed professional surveyor; or
- (2) If the elevation used to determine the required elevation of the lowest floor was determined in accordance with LDR Section 10.1.5(B)(3)(b) the documentation of height of the lowest floor above highest adjacent grade, prepared by the owner or the owner's authorized agent.

(E) **Buildings, Structures and Facilities Exempt from the Florida Building Code, Final Inspection:** As part of the final inspection, the owner or owner's authorized agent shall submit to the Floodplain Administrator a final certification of elevation of the lowest floor or final documentation of the height of the lowest floor above the highest adjacent grade; such certifications and documentations shall be prepared as specified in LDR Section 10.1.6(D).

(F) **Manufactured Home:** The Floodplain Administrator shall inspect manufactured homes that are installed or replaced in flood hazard areas to determine compliance with the requirements of the Floodplain Management Regulations and the conditions of the issued permit. Upon placement of a manufactured home, certification of the elevation of the lowest floor shall be submitted to the Floodplain Administrator.

### **Section 10.1.7 Variances and Appeals:**

**(A) General:** The City Council or its designee shall hear and decide on requests for appeals and requests for variances from the strict application of the Floodplain Management Regulations. Pursuant to section 553.73(5), F.S., the Board of Adjustment shall hear and decide on requests for appeals and requests for variances from the strict application of the flood resistant construction requirements of the Florida Building Code.

**(B) Appeals:** The City Council or its designee shall hear and decide appeals when it is alleged there is an error in any requirement, decision, or determination made by the Floodplain Administrator in the administration and enforcement of the Floodplain Management Regulations. Any person aggrieved by the decision may appeal such decision to the Circuit Court, as provided by Florida Statutes.

**(C) Limitations on Authority to Grant Variances:** The City Council or its designee shall base its decisions on variances on technical justifications submitted by applicants, the considerations for issuance in LDR Section 10.1.7(G) and the conditions of issuance set forth in LDR Section 10.1.7(H), and the comments and recommendations of the Floodplain Administrator and the Building Official. The Board of Adjustment has the right to attach such conditions as it deems necessary to further the purposes and objectives of the Floodplain Management Regulations.

**(D) Restrictions in Floodways:** A variance shall not be issued for any proposed development in a floodway if any increase in base flood elevations would result, as evidenced by the applicable analyses and certifications required in LDR Section 10.1.5(C).

**(E) Historic Buildings:** A variance is authorized to be issued for the repair, improvement, or rehabilitation of a historic building that is determined eligible for the exception to the flood resistant construction requirements of the Florida Building Code, Existing Building, Chapter 12 Historic Buildings, upon a determination that the proposed repair, improvement, or rehabilitation will not preclude the building's continued designation as a historic building and the variance is the minimum necessary to preserve the historic character and design of the building. If the proposed work precludes the building's continued designation as a historic building, a variance shall not be granted and the building and any repair, improvement, and rehabilitation shall be subject to the requirements of the Florida Building Code.

**(F) Functionally Dependent Uses:** A variance is authorized to be issued for the construction or substantial improvement necessary for the conduct of a functionally dependent use, as defined in the Floodplain Management Regulations, provided the variance meets the requirements of LDR Section 10.1.7(D), is the minimum necessary considering the flood hazard, and all due consideration has been given to use of methods and materials that minimize flood damage during occurrence of the base flood.

**(G) Considerations for Issuance of Variances:** In reviewing requests for variances, the Board of Adjustment shall consider all technical evaluations, all relevant factors, all other applicable provisions of the Florida Building Code, the Floodplain Management Regulations, and the following:

- (1) The danger that materials and debris may be swept onto other lands resulting in further injury or damage;
- (2) The danger to life and property due to flooding or erosion damage;

- (3) The susceptibility of the proposed development, including contents, to flood damage and the effect of such damage on current and future owners;
  - (4) The importance of the services provided by the proposed development to the community;
  - (5) The availability of alternate locations for the proposed development that are subject to lower risk of flooding or erosion;
  - (6) The compatibility of the proposed development with existing and anticipated development;
  - (7) The relationship of the proposed development to the comprehensive plan and floodplain management program for the area;
  - (8) The safety of access to the property in times of flooding for ordinary and emergency vehicles;
  - (9) The expected heights, velocity, duration, rate of rise and debris and sediment transport of the floodwaters and the effects of wave action, if applicable, expected at the site; and
  - (10) The costs of providing governmental services during and after flood conditions including maintenance and repair of public utilities and facilities such as sewer, gas, electrical and water systems, streets and bridges.
- (H) **Conditions for Issuance of Variances:** Variances shall be issued only upon:
- (1) Submission by the applicant, of a showing of good and sufficient cause that the unique characteristics of the size, configuration, or topography of the site limit compliance with any provision of the Floodplain Management Regulations or the required elevation standards;
  - (2) Determination by the Board of Adjustment that:
    - a. Failure to grant the variance would result in exceptional hardship due to the physical characteristics of the land that render the lot undevelopable; increased costs to satisfy the requirements or inconvenience do not constitute hardship;
    - b. The granting of a variance will not result in increased flood heights, additional threats to public safety, extraordinary public expense, nor create nuisances, cause fraud on or victimization of the public or conflict with existing local laws and ordinances; and
    - c. The variance is the minimum necessary, considering the flood hazard, to afford relief;
  - (3) Receipt of a signed statement by the applicant that the variance, if granted, shall be recorded in the Office of the Clerk of the Court in such a manner that it appears in the chain of title of the affected parcel of land; and
  - (4) If the request is for a variance to allow construction of the lowest floor of a new building, or substantial improvement of a building below the required elevation, a copy in the record of a written notice from the Floodplain Administrator to the applicant for the variance, specifying the difference between the base flood elevation and the proposed elevation of the lowest floor, stating that the cost of federal flood insurance will be commensurate with the increased risk resulting from the reduced floor elevation (up to amounts as high as \$25 for \$100 of insurance coverage), and stating that construction below the base flood elevation increases risks to life and property.

**Section 10.1.8 Violations:**

- (A) **Violations:** Any development that is not within the scope of the Florida Building Code but that

is regulated by the Floodplain Management Regulations that is performed without an issued permit, that is in conflict with an issued permit, or that does not fully comply with the Floodplain Management Regulations, shall be deemed a violation of the Floodplain Management Regulations. A building or structure without the documentation of elevation of the lowest floor, other required design certifications, or other evidence of compliance required by the Floodplain Management Regulations or the Florida Building Code is presumed to be a violation until such time as that documentation is provided.

**(B) Authority:** For development that is not within the scope of the Florida Building Code but that is regulated by the Floodplain Management Regulations and that is determined to be a violation, the Floodplain Administrator is authorized to serve notices of violation or stop work orders to owners of the property involved, to the owner's agent, or to the person or persons performing the work.

**(C) Unlawful Continuance:** Any person who shall continue any work after having been served with a notice of violation or a stop work order, except such work as that person is directed to perform to remove or remedy a violation or unsafe condition, shall be subject to penalties as prescribed by law.

## **ARTICLE 10.2 DEFINITIONS**

### **Section 10.2.1 General.**

**(A) Scope:** Unless otherwise expressly stated, the following words and terms shall, for the purposes of the Floodplain Management Regulations, have the meanings shown in this section.

**(B) Terms Defined in the Florida Building Code:** Where terms are not defined in the Floodplain Management Regulations and are defined in the Florida Building Code, such terms shall have the meanings ascribed to them in that code.

**(C) Terms Not Defined:** Where terms are not defined in the Floodplain Management Regulations or the Florida Building Code, such terms shall have ordinarily accepted meanings such as the context implies.

### **Section 10.2.2 Definitions:**

**Appeal** a request for a review of the Floodplain Administrator's interpretation of any provision of the Floodplain Management Regulations.

**ASCE 24** is a standard titled Flood Resistant Design and Construction that is referenced by the Florida Building Code. ASCE 24 is developed and published by the American Society of Civil Engineers, Reston, VA.

**Base flood** is a flood having a 1-percent chance of being equaled or exceeded in any given year. [Also defined in FBC, B, Section 202.] The base flood is commonly referred to as the "100-year flood" or the "1-percent-annual chance flood".

**Base flood elevation** the elevation of the base flood, including wave height, relative to the National Geodetic Vertical Datum (NGVD), North American Vertical Datum (NAVD) or other datum specified on the Flood Insurance Rate Map (FIRM). [Also defined in FBC, B, Section 202.]

**Basement** is the portion of a building having its floor subgrade (below ground level) on all sides. [Also defined in FBC, B, Section 202.]

**Crown of road** is the elevation of the highest surface of the street pavement within the right-of-way

abutting the property or the elevation approved by the Floodplain Administrator.

**Design flood** is the flood associated with the greater of the following two areas: [Also defined in FBC, B, Section 202.]

- (1) Area with a floodplain subject to a 1-percent or greater chance of flooding in any year; or
- (2) Area designated as a flood hazard area on the community's flood hazard map, or otherwise legally designated.

**Design flood elevation** is the elevation of the "design flood," including wave height, relative to the datum specified on the community's legally designated flood hazard map. In areas designated as Zone AO, the design flood elevation shall be the elevation of the highest existing grade of the building's perimeter plus the depth number (in feet) specified on the flood hazard map. In areas designated as Zone AO where the depth number is not specified on the map, the depth number shall be taken as being equal to 2 feet. [Also defined in FBC, B, Section 202.]

**Development** is any man-made change to improved or unimproved real estate, including but not limited to, buildings or other structures, tanks, temporary structures, temporary or permanent storage of equipment or materials, mining, dredging, filling, grading, paving, excavations, drilling operations or any other land disturbing activities.

**Existing Building and Existing Structure** is any buildings and structures for which the "start of construction" commenced before January 31, 1979. [Also defined in FBC, B, Section 202.]

**Existing Manufactured Home Park or Subdivision** is a manufactured home park or subdivision for which the construction of facilities for servicing the lots on which the manufactured homes are to be affixed (including, at a minimum, the installation of utilities, the construction of streets, and either final site grading or the pouring of concrete pads) is completed before January 31, 1979.

**Expansion to an Existing Manufactured Home Park or Subdivision** is the preparation of additional sites by the construction of facilities for servicing the lots on which the manufactured homes are to be affixed (including the installation of utilities, the construction of streets, and either final site grading or the pouring of concrete pads).

**Federal Emergency Management Agency (FEMA)** is the federal agency that, in addition to carrying out other functions, administers the National Flood Insurance Program.

**Flood or flooding** is a general and temporary condition of partial or complete inundation of normally dry land from: [Also defined in FBC, B, Section 202.]

- (1) The overflow of inland or tidal waters.
- (2) The unusual and rapid accumulation or runoff of surface waters from any source.

**Flood Damage-Resistant Materials** is any construction material capable of withstanding direct and prolonged contact with floodwaters without sustaining any damage that requires more than cosmetic repair. [Also defined in FBC, B, Section 202.]

**Flood hazard area.** The greater of the following two areas: [Also defined in FBC, B, Section 202.]

- (1) The area within a floodplain subject to a 1-percent or greater chance of flooding in any year.
- (2) The area designated as a flood hazard area on the community's flood hazard map, or otherwise

legally designated.

**Flood Insurance Rate Map (FIRM)** is the official map of the community on which the Federal Emergency Management Agency has delineated both special flood hazard areas and the risk premium zones applicable to the community. [Also defined in FBC, B, Section 202.]

**Flood Insurance Study (FIS)** is the official report provided by the Federal Emergency Management Agency that contains the Flood Insurance Rate Map, the Flood Boundary and Floodway Map (if applicable), the water surface elevations of the base flood, and supporting technical data. [Also defined in FBC, B, Section 202.]

**Floodplain Administrator** is the office or position designated and charged with the administration and enforcement of the Floodplain Management Regulations (may be referred to as the Floodplain Manager). Floodplain development permit or approval. An official document or certificate issued by the community, or other evidence of approval or concurrence, which authorizes performance of specific development activities that are located in flood hazard areas and that are determined to be compliant with the Floodplain Management Regulations.

**Florida Building Code** is the family of codes adopted by the Florida Building Commission, including: Florida Building Code, Building; Florida Building Code, Residential; Florida Building Code, Existing Building; Florida Building Code, Mechanical; Florida Building Code, Plumbing; Florida Building Code, Fuel Gas.

**Functionally Dependent Use** is a use which cannot perform its intended purpose unless it is located or carried out in close proximity to water, including only docking facilities, port facilities that are necessary for the loading and unloading of cargo or passengers, and ship building and ship repair facilities; the term does not include long-term storage or related manufacturing facilities.

**Highest Adjacent Grade** is the highest natural elevation of the ground surface prior to construction next to the proposed walls or foundation of a structure.

**Historic Structure** is any structure that is determined eligible for the exception to the flood hazard area requirements of the Florida Building Code, Existing Building, Chapter 12 Historic Buildings.

**Letter of Map Change (LOMC)** is an official determination issued by FEMA that amends or revises an effective Flood Insurance Rate Map or Flood Insurance Study. Letters of Map Change include:

**Letter of Map Amendment (LOMA)** is an amendment based on technical data showing that a property was incorrectly included in a designated special flood hazard area. A LOMA amends the current effective Flood Insurance Rate Map and establishes that a specific property, portion of a property, or structure is not located in a special flood hazard area.

**Letter of Map Revision (LOMR)** is a revision based on technical data that may show changes to flood zones, flood elevations, special flood hazard area boundaries and floodway delineations, and other planimetric features.

**Letter of Map Revision Based on Fill (LOMR-F)** is a determination that a structure or parcel of land has been elevated by fill above the base flood elevation and is, therefore, no longer located within the special flood hazard area. In order to qualify for this determination, the fill must have

been permitted and placed in accordance with the community's floodplain management regulations.

**Conditional Letter of Map Revision (CLOMR)** is a formal review and comment as to whether a proposed flood protection project or other project complies with the minimum NFIP requirements for such projects with respect to delineation of special flood hazard areas. A CLOMR does not revise the effective Flood Insurance Rate Map or Flood Insurance Study; upon submission and approval of certified as-built documentation, a Letter of Map Revision may be issued by FEMA to revise the effective FIRM.

**Light-duty truck.** As defined in 40 C.F.R. 86.082-2, any motor vehicle rated at 8,500 pounds Gross Vehicular Weight Rating or less which has a vehicular curb weight of 6,000 pounds or less and which has a basic vehicle frontal area of 45 square feet or less, which is:

- (1) Designed primarily for purposes of transportation of property or is a derivation of such a vehicle,  
or
- (2) Designed primarily for transportation of persons and has a capacity of more than 12 persons, or
- (3) Available with special features enabling off-street or off-highway operation and use.

**Lowest Floor** is the lowest floor of the lowest enclosed area of a building or structure, including basement, but excluding any unfinished or flood-resistant enclosure, other than a basement, usable solely for vehicle parking, building access or limited storage provided that such enclosure is not built so as to render the structure in violation of the non-elevation requirements of the Florida Building Code or ASCE 24. [Also defined in FBC, B, Section 202.]

**Manufactured Home** is a structure, transportable in one or more sections, which is eight (8) feet or more in width and greater than four hundred (400) square feet, and which is built on a permanent, integral chassis and is designed for use with or without a permanent foundation when attached to the required utilities. The term "manufactured home" does not include a "recreational vehicle" or "park trailer". [Also defined in 15C-1.0101, F.A.C.]

**Manufactured Home Park or Subdivision** is a parcel (or contiguous parcels) of land divided into two or more manufactured home lots for rent or sale.

**Market Value** is the price at which a property will change hands between a willing buyer and a willing seller, neither party being under compulsion to buy or sell and both having reasonable knowledge of relevant facts. As used in the Floodplain Management Regulations, the term refers to the market value of buildings and structures, excluding the land and other improvements on the parcel. Market value may be established by a qualified independent appraiser, Actual Cash Value (replacement cost depreciated for age and quality of construction), or tax assessment value adjusted to approximate market value by a factor provided by the Property Appraiser.

**New Construction** for the purposes of administration of the Floodplain Management Regulations and the flood resistant construction requirements of the Florida Building Code, structures for which the "start of construction" commenced on or after January 31, 1979 and includes any subsequent improvements to such structures.

***New manufactured Home Park or Subdivision*** is a manufactured home park or subdivision for which the construction of facilities for servicing the lots on which the manufactured homes are to be affixed (including at a minimum, the installation of utilities, the construction of streets, and either final site grading or the pouring of concrete pads) is completed on or after January 31, 1979.

***Park Trailer*** is a transportable unit which has a body width not exceeding fourteen (14) feet and which is built on a single chassis and is designed to provide seasonal or temporary living quarters when connected to utilities necessary for operation of installed fixtures and appliances. [Defined in section 320.01, F.S.]

***Recreational Vehicle*** is a vehicle, including a park trailer, which is: [See section 320.01, F.S.)

- (1) Built on a single chassis;
- (2) Four hundred (400) square feet or less when measured at the largest horizontal projection;
- (3) Designed to be self-propelled or permanently towable by a light-duty truck; and
- (4) Designed primarily not for use as a permanent dwelling but as temporary living quarters for recreational, camping, travel, or seasonal use.

***Special Flood Hazard Area*** is an area in the floodplain subject to a 1 percent or greater chance of flooding in any given year. Special flood hazard areas are shown on FIRMs as Zone A, AO, A1-A30, AE, A99, AH, V1-V30, VE or V. [Also defined in FBC, B Section 202.]

***Start of Construction*** is the date of issuance of permits for new construction and substantial improvements, provided the actual start of construction, repair, reconstruction, rehabilitation, addition, placement, or other improvement is within 180 days of the date of the issuance. The actual start of construction means either the first placement of permanent construction of a building (including a manufactured home) on a site, such as the pouring of slab or footings, the installation of piles, the construction of columns. Permanent construction does not include land preparation (such as clearing, grading, or filling), the installation of streets or walkways, excavation for a basement, footings, piers, or foundations, the erection of temporary forms or the installation of accessory buildings such as garages or sheds not occupied as dwelling units or not part of the main buildings. For a substantial improvement, the actual "start of construction" means the first alteration of any wall, ceiling, floor or other structural part of a building, whether or not that alteration affects the external dimensions of the building. [Also defined in FBC, B Section 202.]

***Substantial Damage*** is damage of any origin sustained by a building or structure whereby the cost of restoring the building or structure to its before-damaged condition would equal or exceed 50 percent of the market value of the building or structure before the damage occurred. [Also defined in FBC, B Section 202.]

***Substantial Improvement*** is any repair, reconstruction, rehabilitation, alteration, addition, or other improvement of a building or structure, the cost of which equals or exceeds 50 percent of the market value of the building or structure before the improvement or repair is started. If the structure has incurred "substantial damage", any repairs are considered substantial improvement regardless of the actual repair work performed. The term does not, however, include either: [Also defined in FBC, B, Section 202.]

- (1) Any project for improvement of a building required to correct existing health, sanitary, or safety



code violations identified by the Building Official and that are the minimum necessary to assure safe living conditions.

- (2) Any alteration of a historic structure provided the alteration will not preclude the structure's continued designation as a historic structure.

**Variance** is a grant of relief from the requirements of the Floodplain Management Regulations, or the flood resistant construction requirements of the Florida Building Code, which permits construction in a manner that would not otherwise be permitted by the Floodplain Management Regulations or the Florida Building Code.

## **ARTICLE 10.3 FLOOD RESISTANT DEVELOPMENT**

### **Section 10.3.1 Buildings and Structures:**

(A) **Design and Construction of Buildings, Structures and Facilities Exempt from the Florida Building Code:** Pursuant to LDR Section 10.1.4(C), buildings, structures, and facilities that are exempt from the Florida Building Code, including substantial improvement or repair of substantial damage of such buildings, structures and facilities, shall be designed and constructed in accordance with the flood load and flood resistant construction requirements of ASCE 24. Structures exempt from the Florida Building Code that are not walled and roofed buildings shall comply with the requirements of LDR Section 10.3.7.

(B) **Minimum Elevation Requirements.** All new buildings shall have the lowest floor shall be elevated to or above eighteen (18) inches above the crown of road or the elevation specified in the Florida Building Code, whichever is higher.

### **Section 10.3.2 Subdivisions:**

(A) **Minimum Requirements:** Subdivision proposals, including proposals for manufactured home parks and subdivisions, shall be reviewed to determine that:

- (1) Such proposals are consistent with the need to minimize flood damage and will be reasonably safe from flooding;
- (2) All public utilities and facilities such as sewer, gas, electric, communications, and water systems are located and constructed to minimize or eliminate flood damage; and
- (3) Adequate drainage is provided to reduce exposure to flood hazards; in Zones AH and AO, adequate drainage paths shall be provided to guide floodwaters around and away from proposed structures.

(B) **Subdivision Plats:** Where any portion of proposed subdivisions, including manufactured home parks and subdivisions, lies within a flood hazard area, the following shall be required:

- (1) Delineation of flood hazard areas, floodway boundaries and flood zones, and design flood elevations, as appropriate, shall be shown on preliminary plats;
- (2) Where the subdivision has more than 50 lots or is larger than 5 acres and base flood elevations are not included on the FIRM, the base flood elevations determined in accordance with LDR Section 10.1.5(B)(1); and
- (3) Compliance with the site improvement and utilities requirements of LDR Section 10.3.3.

### **Section 10.3.3 Site Improvements, Utilities and Limitations:**

(A) **Minimum Requirements:** All proposed new development shall be reviewed to determine that:

- (1) Such proposals are consistent with the need to minimize or eliminate flood damage and will be reasonably safe from flooding;
- (2) All public utilities and facilities such as sewer, gas, electric, communications, and water systems are located and constructed to minimize or eliminate flood damage; and
- (3) Adequate drainage is provided to reduce exposure to flood hazards; in Zones AH and AO, adequate drainage paths shall be provided to guide floodwaters around and away from proposed structures.

(B) **Sanitary Sewage Facilities:** All new and replacement sanitary sewage facilities, private sewage treatment plants (including all pumping stations and collector systems), and on-site waste disposal systems shall be designed in accordance with the standards for onsite sewage treatment and disposal systems in Chapter 64E-6, F.A.C. and ASCE 24 Chapter 7 to minimize or eliminate infiltration of floodwaters into the facilities and discharge from the facilities into flood waters, and impairment of the facilities and systems.

(C) **Water Supply Facilities:** All new and replacement water supply facilities shall be designed in accordance with the water well construction standards in Chapter 62-532.500, F.A.C. and ASCE 24 Chapter 7 to minimize or eliminate infiltration of floodwaters into the systems.

(D) **Limitations on Placement of Fill:** Subject to the limitations of the Floodplain Management Regulations, fill shall be designed to be stable under conditions of flooding including rapid rise and rapid drawdown of floodwaters, prolonged inundation, and protection against flood-related erosion and scour. In addition to these requirements, if intended to support buildings and structures (Zone A only), fill shall comply with the requirements of the Florida Building Code.

### **Section 10.3.4 Manufactured Homes:**

(A) **General:** All manufactured homes installed in flood hazard areas shall be installed by an installer that is licensed pursuant to section 320.8249, F.S., and shall comply with the requirements of Chapter 15C-1, F.A.C. and the requirements of the Floodplain Management Regulations.

(B) **Foundations:** All new manufactured homes and replacement manufactured homes installed in flood hazard areas shall be installed on permanent, reinforced foundations that are designed in accordance with the foundation requirements of the Florida Building Code, Residential Section R322.2 and the Floodplain Management Regulations. Foundations for manufactured homes subject to LDR Section 10.3.4(F) are permitted to be reinforced piers or other foundation elements of at least equivalent strength.

(C) **Anchoring:** All new manufactured homes and replacement manufactured homes shall be installed using methods and practices which minimize flood damage and shall be securely anchored to an adequately anchored foundation system to resist flotation, collapse or lateral movement. Methods of anchoring include, but are not limited to, use of over-the-top or frame ties to ground anchors. This anchoring requirement is in addition to applicable state and local anchoring requirements for wind resistance.

(D) **Elevation:** Manufactured homes that are placed, replaced, or substantially improved shall comply with LDR Section 10.3.4(E) or 10.3.4(F) as applicable.

(E) **General Elevation Requirement:** Unless subject to the requirements of LDR Section 10.3.4(F), all manufactured homes that are placed, replaced, or substantially improved on sites located: (a) outside of a manufactured home park or subdivision; (b) in a new manufactured home park or subdivision; (c) in an expansion to an existing manufactured home park or subdivision; or (d) in an existing manufactured home park or subdivision upon which a manufactured home has incurred "substantial damage" as the result of a flood, shall be elevated such that the bottom of the frame is at or above the elevation required, as applicable to the flood hazard area, in the Florida Building Code, Residential Section R322.2 (Zone A).

(F) **Elevation Requirement for Certain Existing Manufactured Home Parks and Subdivisions:**

Manufactured homes that are not subject to LDR Section 10.3.4(E) including manufactured homes that are placed, replaced, or substantially improved on sites located in an existing manufactured home park or subdivision, unless on a site where substantial damage as result of flooding has occurred, shall be elevated such that either the:

- (1) Bottom of the frame of the manufactured home is at or above the elevation required in the Florida Building Code, Residential Section R322.2 (Zone A); or
- (2) Bottom of the frame is supported by reinforced piers or other foundation elements of at least equivalent strength that are not less than 36 inches in height above grade.

(G) **Enclosures:** Enclosed areas below elevated manufactured homes shall comply with the requirements of the Florida Building Code, Residential Section R322.2.

(H) **Utility Equipment:** Utility equipment that serves manufactured homes, including electric, heating, ventilation, plumbing, and air conditioning equipment and other service facilities, shall comply with the requirements of the Florida Building Code, Residential Section R322.

### **Section 10.3.5 Recreational Vehicles and Park Trailers.**

(A) **Temporary Placement:** Recreational vehicles and park trailers placed temporarily in flood hazard areas shall:

- (1) Be on the site for fewer than 180 consecutive days; or
- (2) Be fully licensed and ready for highway use, which means the recreational vehicle or park model is on wheels or jacking system, is attached to the site only by quick-disconnect type utilities and security devices, and has no permanent attachments such as additions, rooms, stairs, decks and porches.

(B) **Permanent Placement:** Recreational vehicles and park trailers that do not meet the limitations in LDR Section 10.3.5(A) for temporary placement shall meet the requirements of LDR Section 10.3.4 for manufactured homes.

### **Section 10.3.6 Tanks:**

(A) **Underground Tanks:** Underground tanks in flood hazard areas shall be anchored to prevent flotation, collapse or lateral movement resulting from hydrodynamic and hydrostatic loads during conditions of the design flood, including the effects of buoyancy assuming the tank is empty.

**(B) Above-Ground Tanks, not Elevated:** Above-ground tanks that do not meet the elevation requirements of LDR Section 10.3.6(C) shall be permitted in flood hazard areas (Zone A), provided the tanks are anchored or otherwise designed and constructed to prevent flotation, collapse or lateral movement resulting from hydrodynamic and hydrostatic loads during conditions of the design flood, including the effects of buoyancy assuming the tank is empty and the effects of flood-borne debris.

**(C) Above-Ground Tanks, Elevated:** Above-ground tanks in flood hazard areas shall be attached to and elevated to or above the design flood elevation on a supporting structure that is designed to prevent flotation, collapse or lateral movement during conditions of the design flood. Tank-supporting structures shall meet the foundation requirements of the applicable flood hazard area.

**(D) Tank Inlets and Vents:** Tank inlets, fill openings, outlets and vents shall be:

- (1) At or above the design flood elevation or fitted with covers designed to prevent the inflow of floodwater or outflow of the contents of the tanks during conditions of the design flood; and
- (2) Anchored to prevent lateral movement resulting from hydrodynamic and hydrostatic loads, including the effects of buoyancy, during conditions of the design flood.

### **Section 10.3.7 Other Development:**

**(A) General Requirements for Other Development:** All development, including man-made changes to improved or unimproved real estate for which specific provisions are not specified in the Floodplain Management Regulations or the Florida Building Code, shall:

- (1) Be located and constructed to minimize flood damage;
- (2) Be anchored to prevent flotation, collapse or lateral movement resulting from hydrostatic loads, including the effects of buoyancy, during conditions of the design flood;
- (3) Be constructed of flood damage-resistant materials; and
- (4) Have mechanical, plumbing, and electrical systems above the design flood elevation or meet the requirements of ASCE 24, except that minimum electric service required to address life safety and electric code requirements is permitted below the design flood elevation provided it conforms to the provisions of the electrical part of building code for wet locations.

**Section 3:** For the purposes of jurisdictional applicability, this Article shall apply in the City of Westlake. This Article shall apply to all applications for development, including building permit applications and subdivision proposals, submitted on or after the effective date of this Article.

**Section 4:** That various sections of the Land Development Regulations of the Code of Ordinances of the City of Westlake, Florida, be and the same are hereby amended to update all cross references that relate to this new Article.

**Section 5:** That should any section or provision of this ordinance or any portion thereof, any paragraph, sentence, or word be declared by a court of competent jurisdiction to be invalid, such decision shall not affect the validity of the remainder hereof as a whole or part thereof other than the part declared to be invalid.

**Section 6:** That all ordinances or parts of ordinances in conflict herewith be, and the same are hereby repealed.

**Section 7:** That this ordinance shall become effective immediately upon its passage on second and final reading.

**PASSED** on this 8<sup>th</sup> day of October, 2018 on first reading by the City Council for the City of Westlake.

**PASSED AND APPROVED** by City Council for the City of Westlake, on this \_\_\_\_\_ day of, November 2018.

---

City of Westlake  
Roger Manning, Mayor

---

Sandra Demarco, City Clerk

---

Approved as to Form and Sufficiency  
Pam E. Booker, City Attorney

## **Ninth Order of Business**

October 8, 2018

## RESOLUTION 2018-28

**A RESOLUTION OF THE CITY COUNCIL FOR THE CITY OF WESTLAKE, FLORIDA, APPROVING THE FINAL PLAT OF WATERS EDGE DRIVE, LOCATED BY METES AND BOUNDS AS A PORTION OF LAND LYING IN SECTION 12, TOWNSHIP 43 EAST, RANGE 40 EAST, IN THE CITY OF WESTLAKE, PALM BEACH COUNTY, FLORIDA, PROVIDING FOR RECORDATION; AND PROVIDING AN EFFECTIVE DATE.**

---

**WHEREAS**, Minto PBLH, LLC, a Florida Limited Liability Company, as the Applicant has requested approval Waters Edge Drive, Final Plat, described by metes and bounds description as a parcel of land lying in Section 12, Township 43 South, Range 40 East, in the City of Westlake, Palm Beach County, Florida, as described in Exhibit "A", attached hereto; and

**WHEREAS**, the City of Westlake has the exclusive jurisdiction to approve the plat pursuant to Florida Statutes, §177.071; and

**WHEREAS**, the application has been reviewed and approved by a Professional Surveyor and Mapper for the City of Westlake, and said Surveyor and Mapper has found the application to be consistent with the requirements under Florida Statutes, Chapter 177; and

**WHEREAS**, the building staff, engineering staff and planning staff for the City of Westlake has reviewed the application, the final plat and the boundary survey, and the collective staff has recommended approval; and

**WHEREAS**, after careful review and consideration, the collective staff has determined that this application has complied with the City of Westlake's interim Land Development Codes and Florida law.

**NOW THEREFORE**, BE IT RESOLVED BY THE CITY COUNCIL FOR THE CITY OF WESTLAKE, FLORIDA, THAT:

**Section 1:** The above recitals are true and correct and are incorporated herein by this reference.

**Section 2:** The City Council for the City of Westlake hereby approves the final plat and boundary survey for Waters Edge Drive, Final Plat, as described in the attached Exhibit "A", containing approximately four (4) acres, which is located in the City of Westlake, and in Palm Beach County, Florida.

**Section 3.** The applicant shall provide a certified copy of the recorded plat and the applicant shall cover the costs of recording the plat in the public records in and for Palm Beach County Florida.

**Section 4:** This resolution shall take effect immediately upon its adoption.

**PASSED AND APPROVED** by City Council for the City of Westlake, on this 8<sup>th</sup> day

of October, 2018.

---

City of Westlake  
Roger Manning, Mayor

---

Sandra Demarco, City Clerk

---

Approved as to Form and Sufficiency  
Pam E. Booker, City Attorney



# WATERS EDGE DRIVE

BEING A PLAT OF A PORTION OF  
SECTION 12, TOWNSHIP 43 SOUTH, RANGE 40 EAST,  
CITY OF WESTLAKE, PALM BEACH COUNTY, FLORIDA

IN WITNESS WHEREOF, MINTO PBLH, LLC, A FLORIDA LIMITED LIABILITY COMPANY HAS CAUSED THESE PRESENTS TO BE SIGNED BY ITS MANAGER AND ITS COMPANY SEAL TO BE AFFIXED HERETO BY AND WITH THE AUTHORITY OF ITS MEMBERS THIS \_\_\_\_ DAY OF \_\_\_\_\_, 2018.

MINTO PBLH, LLC  
A FLORIDA LIMITED LIABILITY COMPANY

WITNESS: \_\_\_\_\_  
PRINT NAME: \_\_\_\_\_

BY: \_\_\_\_\_  
JOHN F. CARTER, MANAGER

WITNESS: \_\_\_\_\_  
PRINT NAME: \_\_\_\_\_

**ACKNOWLEDGEMENT**  
STATE OF FLORIDA  
COUNTY OF PALM BEACH

BEFORE ME PERSONALLY APPEARED JOHN F. CARTER WHO IS PERSONALLY KNOWN TO ME, OR HAS PRODUCED \_\_\_\_\_ AS IDENTIFICATION, AND WHO EXECUTED THE FOREGOING INSTRUMENT AS MANAGER OF MINTO PBLH, LLC, A FLORIDA LIMITED LIABILITY COMPANY, AND SEVERALLY ACKNOWLEDGED TO AND BEFORE ME THAT HE EXECUTED SUCH INSTRUMENT AS SUCH OFFICER OF SAID COMPANY, AND THAT THE SEAL AFFIXED TO SAID INSTRUMENT IS THE CORPORATE SEAL OF SAID COMPANY AND THAT IT WAS AFFIXED TO SAID INSTRUMENT BY DUE AND REGULAR CORPORATE AUTHORITY, AND THAT SAID INSTRUMENT IS THE FREE ACT AND DEED OF SAID COMPANY.

WITNESS MY HAND AND OFFICIAL SEAL THIS \_\_\_\_ DAY OF \_\_\_\_\_, 2018.

MY COMMISSION EXPIRES: \_\_\_\_\_

\_\_\_\_\_  
NOTARY PUBLIC STATE OF FLORIDA  
PRINT NAME: \_\_\_\_\_  
COMMISSION NO. \_\_\_\_\_

(SEAL)

**ACCEPTANCE OF DEDICATION**

STATE OF FLORIDA  
COUNTY OF PALM BEACH

THE CITY OF WESTLAKE, FLORIDA, A MUNICIPAL CORPORATION, HEREBY ACCEPTS THE DEDICATION OF ROAD RIGHT-OF-WAY AS STATED AND SHOWN HEREON, AND HEREBY ACCEPTS ITS MAINTENANCE OBLIGATIONS FOR SAME AS STATED HEREON, DATED THIS \_\_\_\_ DAY OF \_\_\_\_\_, 2018.

CITY OF WESTLAKE  
A MUNICIPAL CORPORATION

WITNESS: \_\_\_\_\_

PRINT NAME: \_\_\_\_\_

BY: \_\_\_\_\_

WITNESS: \_\_\_\_\_  
CITY MAYOR, ROGER MANNING

PRINT NAME: \_\_\_\_\_

**ACKNOWLEDGEMENT**  
STATE OF FLORIDA  
COUNTY OF PALM BEACH

BEFORE ME PERSONALLY APPEARED \_\_\_\_\_ (PRINTED NAME) WHO IS PERSONALLY KNOWN TO ME, OR HAS PRODUCED \_\_\_\_\_ AS IDENTIFICATION, AND WHO EXECUTED THE FOREGOING INSTRUMENT AS \_\_\_\_\_ OF THE CITY OF WESTLAKE, A MUNICIPAL CORPORATION, AND SEVERALLY ACKNOWLEDGED TO AND BEFORE ME THAT [HE] [SHE] EXECUTED SUCH INSTRUMENT AS SUCH OFFICER OF SAID CORPORATION, AND THAT THE SEAL AFFIXED TO THE FOREGOING INSTRUMENT IS THE CORPORATE SEAL (IF AVAILABLE) OF SAID CORPORATION AND THAT IT WAS AFFIXED TO SAID INSTRUMENT BY DUE AND REGULAR CORPORATE AUTHORITY, AND THAT SAID INSTRUMENT IS THE FREE ACT AND DEED OF SAID CORPORATION.

WITNESS MY HAND AND OFFICIAL SEAL THIS \_\_\_\_ DAY OF \_\_\_\_\_, 2018.

MY COMMISSION EXPIRES: \_\_\_\_\_

\_\_\_\_\_  
NOTARY PUBLIC STATE OF FLORIDA  
PRINT NAME: \_\_\_\_\_  
COMMISSION NO. \_\_\_\_\_

(SEAL)

**ACCEPTANCE OF DEDICATIONS & RESERVATIONS**

STATE OF FLORIDA  
COUNTY OF PALM BEACH

SEMINOLE IMPROVEMENT DISTRICT, AN INDEPENDENT SPECIAL DISTRICT OF THE STATE OF FLORIDA, HEREBY ACCEPTS THE DEDICATIONS AND RESERVATIONS TO SAID DISTRICT AS STATED AND SHOWN HEREON, AND HEREBY ACCEPTS ITS MAINTENANCE OBLIGATIONS FOR SAME AS STATED HEREON, DATED THIS \_\_\_\_ DAY OF \_\_\_\_\_, 2018.

SEMINOLE IMPROVEMENT DISTRICT, AN INDEPENDENT  
SPECIAL DISTRICT OF THE STATE OF FLORIDA

WITNESS: \_\_\_\_\_

BY: \_\_\_\_\_  
SCOTT MASSEY, PRESIDENT

PRINT NAME: \_\_\_\_\_

WITNESS: \_\_\_\_\_

PRINT NAME: \_\_\_\_\_

MINTO PBLH, LLC  
CITY OF WESTLAKE  
ACCEPTANCE

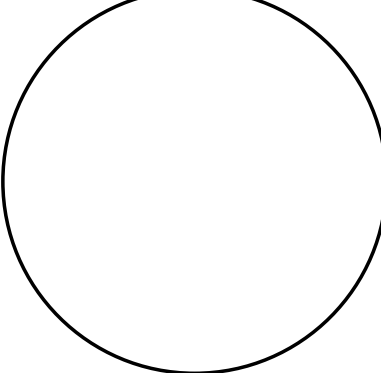

CITY OF WESTLAKE  
ACCEPTANCE

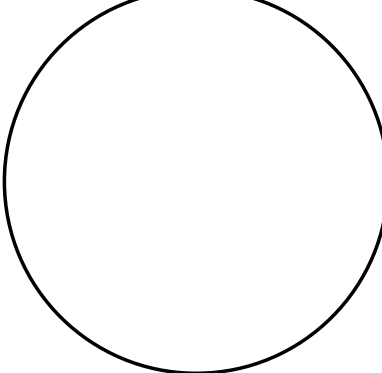

SEMINOLE IMPROVEMENT  
DISTRICT

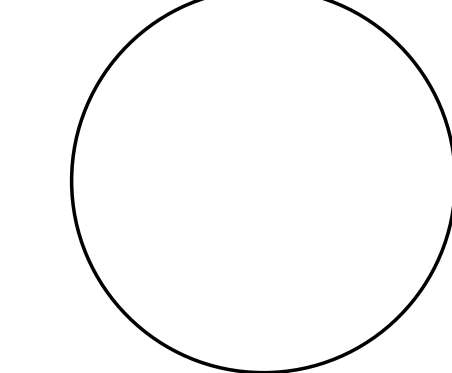

MORTGAGEE'S JOINDER  
AND CONSENT

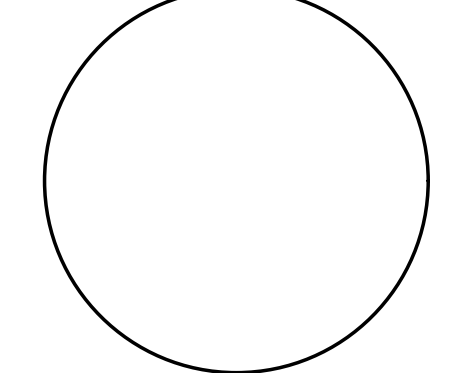

CITY OF WESTLAKE  
APPROVAL

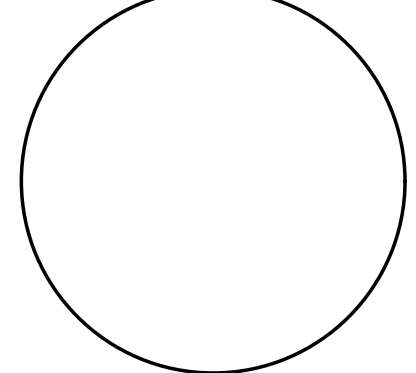

SURVEYOR'S SEAL

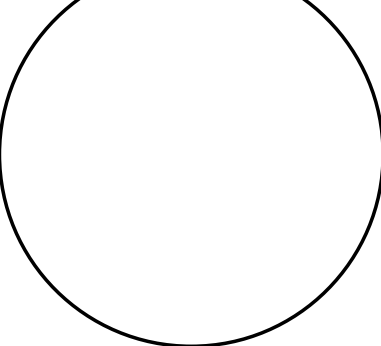
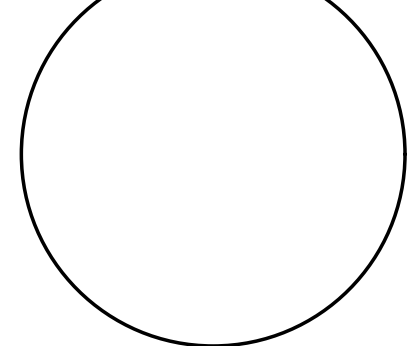
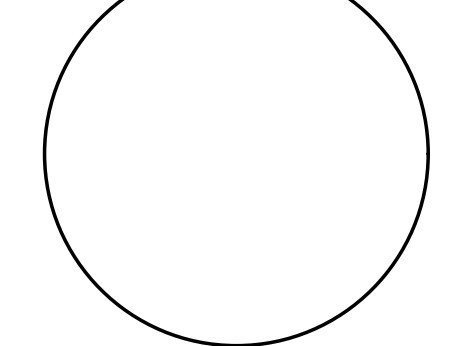
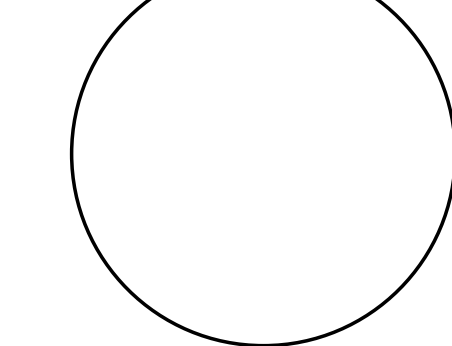
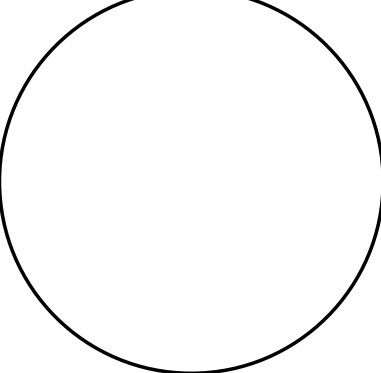

MORTGAGEE'S JOINDER  
AND CONSENT

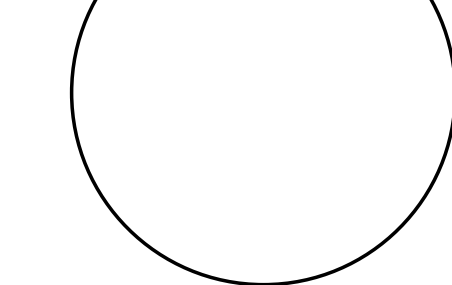

CITY OF WESTLAKE  
APPROVAL

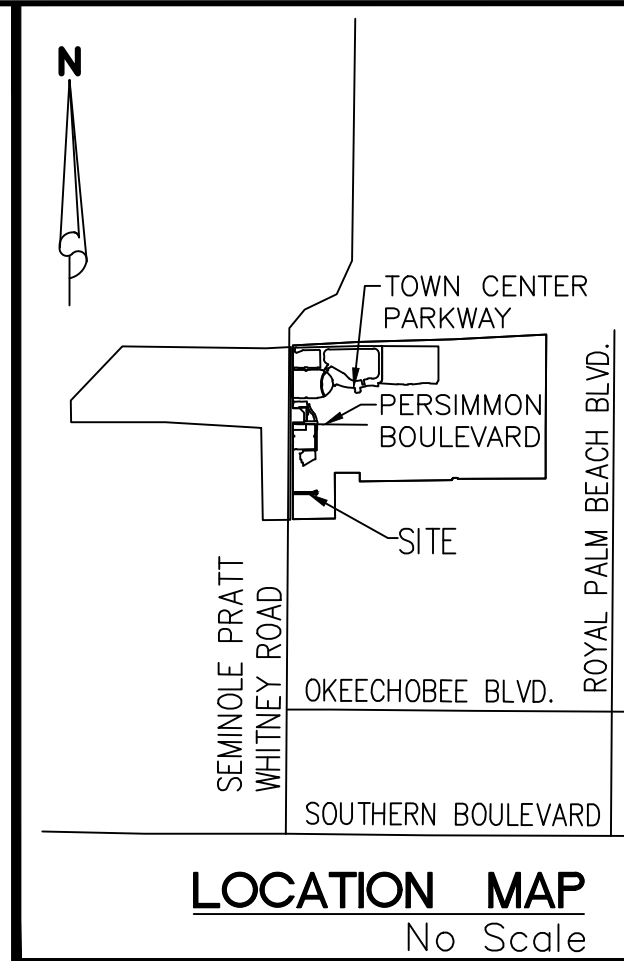
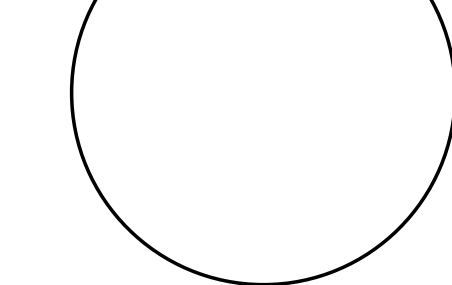
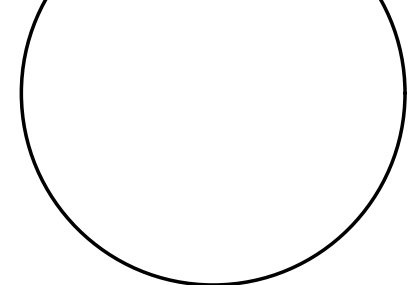

STATE OF FLORIDA }  
COUNTY OF PALM BEACH } S.S.  
THIS INSTRUMENT WAS FILED FOR  
RECORD AT \_\_\_\_\_ M.  
THIS \_\_\_\_ DAY OF \_\_\_\_\_  
2018, AND DULY RECORDED IN  
PLAT BOOK NO. \_\_\_\_\_  
ON PAGE \_\_\_\_\_

SHARON R. BOCK,  
CLERK AND COMPTROLLER

BY: \_\_\_\_\_, D.C.

**AREA TABLE (ACRES)**

|                       |               |
|-----------------------|---------------|
| 1. ROADWAY            | = 3.382       |
| 2. OPEN SPACE TRACT 1 | = 0.300       |
| 3. OPEN SPACE TRACT 2 | = 0.357       |
| TOTAL                 | = 4.039 ACRES |

**SURVEYORS NOTES**

- PERMANENT REFERENCE MONUMENTS ARE SHOWN THUS: "■" A 1 1/2" BRASS DISK STAMPED "PRM LB7768" SET IN A 4"x4" CONCRETE MONUMENT. PERMANENT CONTROL POINTS ARE SHOWN AS THUS: "⊙" A MAGNETIC NAIL AND DISK STAMPED "PCP LB7768". MONUMENTS ARE SHOWN AS THUS: "●" A 1/2" IRON ROD WITH CAP STAMPED "LB7768". (UNLESS OTHERWISE NOTED)
- BEARINGS SHOWN HEREON ARE BASED ON THE NORTH BOUNDARY OF SECTION 6, TOWNSHIP 43 SOUTH, RANGE 41 EAST, HAVING A GRID BEARING OF S.89°48'53"E. BEARINGS SHOWN HEREON, REFER TO THE STATE PLANE COORDINATE SYSTEM, NORTH AMERICAN DATUM OF 1983 (NAD 83 / 07) FOR THE EAST ZONE OF FLORIDA. SAID BASIS OF BEARING IS THE SAME IN THE NORTH AMERICAN DATUM OF 1983 (NAD 83 / 90).
- NO BUILDING OR ANY KIND OF CONSTRUCTION OR TREES OR SHRUBS SHALL BE PLACED ON ANY EASEMENT WITHOUT PRIOR WRITTEN CONSENT OF ALL EASEMENT BENEFICIARIES AND ALL APPLICABLE CITY APPROVALS OR PERMITS AS REQUIRED FOR SUCH ENCROACHMENTS. THERE WILL BE NO ABOVE GROUND ENCROACHMENTS WHERE LAKE MAINTENANCE EASEMENTS AND UTILITY EASEMENTS OVERLAP.
- THE BUILDING SETBACKS SHALL BE AS REQUIRED BY THE CITY OF WESTLAKE ZONING REGULATIONS.
- NOTICE: THIS PLAT, AS RECORDED IN ITS GRAPHIC FORM, IS THE OFFICIAL DEPICTION OF THE SUBDIVIDED LANDS DESCRIBED HEREIN AND WILL IN NO CIRCUMSTANCES BE SUPPLANTED IN AUTHORITY BY ANY OTHER GRAPHIC OR DIGITAL FORM OF THE PLAT. THERE MAY BE ADDITIONAL RESTRICTIONS THAT ARE NOT RECORDED ON THIS PLAT THAT MAY BE FOUND IN THE PUBLIC RECORDS OF PALM BEACH COUNTY.
- IN THOSE CASES WHERE EASEMENTS OF DIFFERENT TYPES CROSS OR OTHERWISE COINCIDE, DRAINAGE EASEMENTS SHALL HAVE FIRST PRIORITY, UTILITY EASEMENTS SHALL HAVE SECOND PRIORITY, ACCESS EASEMENTS SHALL HAVE THIRD PRIORITY, AND ALL OTHER EASEMENTS SHALL BE SUBORDINATE TO THESE WITH THEIR PRIORITIES BEING DETERMINED BY USE RIGHTS GRANTED.
- ALL LINES INTERSECTING CIRCULAR CURVES ARE RADIAL UNLESS OTHERWISE NOTED.
- COORDINATES SHOWN HEREON ARE FLORIDA STATE PLANE GRID DATUM = NAD83 2007 ADJUSTMENT  
ZONE = FLORIDA EAST  
LINEAR UNITS = US SURVEY FEET  
COORDINATE SYSTEM = 1983 STATE PLANE  
PROJECTION = TRANSVERSE MERCATOR  
ALL DISTANCES ARE GROUND  
SCALE FACTOR: 1.0000  
GROUND DISTANCE X SCALE FACTOR = GRID DISTANCE  
PLAT BEARING = GRID BEARING  
NO ROTATION  
ALL TIES TO SECTION CORNERS AND QUARTER CORNERS ARE GENERATED FROM MEASURED VALUES

**SURVEYOR & MAPPER'S CERTIFICATE**

THIS IS TO CERTIFY THAT THE PLAT SHOWN HEREON IS A TRUE AND CORRECT REPRESENTATION OF A SURVEY MADE UNDER MY RESPONSIBLE DIRECTION AND SUPERVISION; THAT SAID SURVEY IS ACCURATE TO THE BEST OF MY KNOWLEDGE AND BELIEF; THAT PERMANENT REFERENCE MONUMENTS ("P.R.M.S") HAVE BEEN PLACED AS REQUIRED BY LAW, AND THAT PERMANENT CONTROL POINTS ("P.C.P.S"), AND MONUMENTS ACCORDING TO SEC. 177.091(9), F.S., WILL BE SET UNDER THE GUARANTEES POSTED WITH THE CITY OF WESTLAKE FOR THE REQUIRED IMPROVEMENTS; AND, FURTHER, THAT THE SURVEY DATA COMPLIES WITH ALL THE REQUIREMENTS OF CHAPTER 177, FLORIDA STATUTES, AS AMENDED, AND THE ORDINANCES OF THE CITY OF WESTLAKE, FLORIDA.

DATE: \_\_\_\_\_  
LUIS J. ORTIZ, P.S.M.  
LICENSE NO. LS7006  
STATE OF FLORIDA

THIS INSTRUMENT PREPARED BY  
LUIS J. ORTIZ, P.S.M.  
LS7006 STATE OF FLORIDA.  
GEOPPOINT SURVEYING, INC.  
4152 WEST BLUE HERON BOULEVARD, SUITE 105,  
RIVIERA BEACH, FLORIDA 33404.  
CERTIFICATE OF AUTHORIZATION NO. LB7768

4152 W. Blue Heron Blvd. Phone: (561) 444-2720  
Suite 105 www.geopointsurvey.com  
Riviera Beach, FL 33404 Licensed Business Number LB 7768  
Sheet No. 1 of 2 Sheets

# WATERS EDGE DRIVE

BEING A PLAT OF A PORTION OF  
SECTION 12, TOWNSHIP 43 SOUTH, RANGE 40 EAST,  
CITY OF WESTLAKE, PALM BEACH COUNTY, FLORIDA

NORTHWEST CORNER SECTION 1-43-40  
FOUND BRASS DISK IN CONCRETE "P.B.C."  
N:884612.3299, E:880484.6585  
NAD83 (2007 ADJUSTMENT)  
CERTIFIED CORNER RECORD #107585

POINT OF COMMENCEMENT  
NORTHEAST CORNER OF  
SECTION 1, TOWNSHIP 43 S., RANGE 40 E.  
SET 3.5" IRON PIPE "PUBLIC LAND SURVEY  
CORNER-TALLAHASSEE MERIDIAN"  
BRASS DISK "10' EAST" SET IN CONCRETE  
FOUND 10' EAST ON SECTION LINE  
N: 884626.7147  
E: 886137.1629  
NAD83 (2007 ADJUSTMENT)  
CERTIFIED CORNER RECORD #107597

SOUTH LINE OF SECTION 31,  
TOWNSHIP 42 S., RANGE 41 E.

BASIS OF BEARING  
NORTH BOUNDARY  
OF SECTION 6,  
TOWNSHIP 43 S., RANGE 41 E.  
S.89°48'53"E., 5270.23'  
(MEASURED)  
S.89°48'52"E., 5270.39'  
(COUNTY)

NORTHEAST CORNER  
SECTION 6-43-41  
FOUND BRASS DISK IN  
CONCRETE "P.B.C."  
N:884609.6818 E:891407.3638  
NAD83 (2007 ADJUSTMENT)  
CERTIFIED CORNER  
RECORD #107591

EAST 1/4 CORNER SECTION 1-43-40  
BRASS DISK IN CONCRETE "P.B.C."  
CERTIFIED CORNER RECORD # 107599  
N:881943.9584 (83/07)  
E:886064.5056 (83/07)

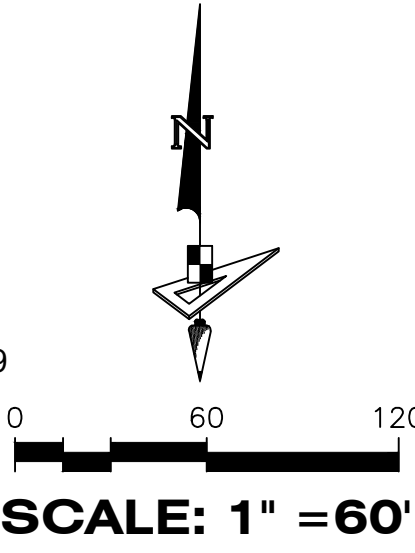

### LEGEND

- P.O.B. ----- POINT OF BEGINNING
- R.P.B. ----- ROAD PLAT BOOK
- R/W ----- RIGHT-OF-WAY
- NAD ----- NORTH AMERICAN DATUM
- P.B.C. ----- PALM BEACH COUNTY
- P.B. ----- PLAT BOOK
- O.R./O.R.B. ----- OFFICIAL RECORDS BOOK
- PG./PGS. ----- PAGE/PAGES
- U.E. ----- UTILITY EASEMENT
- D.B. ----- DEED BOOK
- FIR ----- FOUND IRON ROD
- R ----- RADIUS
- L ----- ARCH LENGTH
- Δ ----- DELTA ANGLE
- O.S.T. ----- OPEN SPACE TRACT
- Q ----- CENTERLINE
- ----- SET PERMANENT REFERENCE MONUMENT
- ----- INDICATES (S.I.R.) SET IRON ROD LB7768
- ⊙ ----- PERMANENT CONTROL POINT

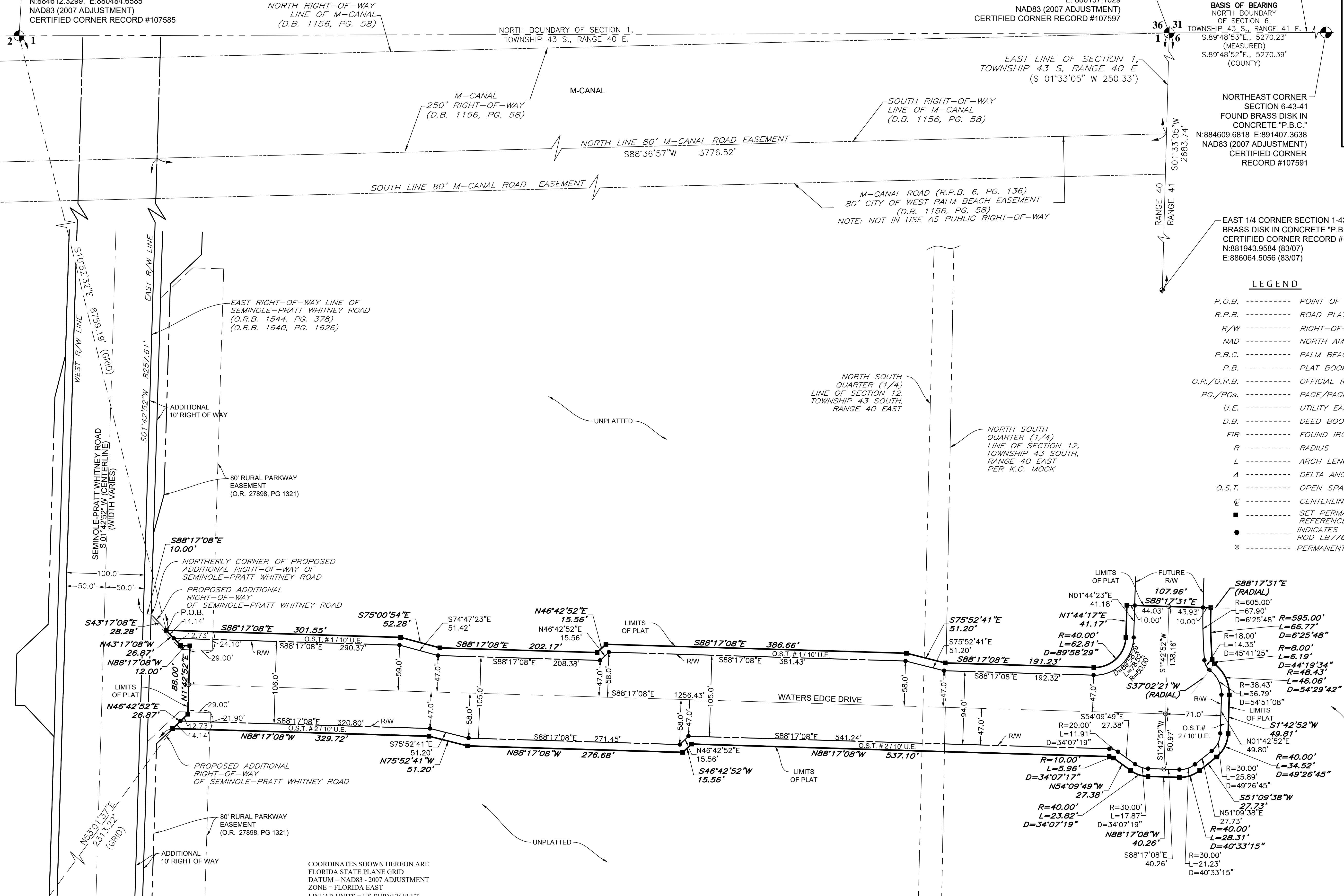

COORDINATES SHOWN HEREON ARE  
FLORIDA STATE PLANE GRID  
DATUM = NAD83 - 2007 ADJUSTMENT  
ZONE = FLORIDA EAST  
LINEAR UNITS = US SURVEY FEET  
COORDINATE SYSTEM = 1983 STATE PLANE  
PROJECTION = TRANSVERSE MERCATOR  
ALL DISTANCES ARE GROUND  
SCALE FACTOR: 1.0000  
GROUND DISTANCE X SCALE FACTOR = GRID DISTANCE  
PLAT BEARING = GRID BEARING  
NO ROTATION  
ALL TIES TO SECTION CORNERS AND QUARTER CORNERS  
ARE GENERATED FROM MEASURED VALUES

NOTICE: THIS PLAT, AS RECORDED IN ITS GRAPHIC FORM, IS THE  
OFFICIAL DEPICTION OF THE SUBDIVIDED LANDS DESCRIBED  
HEREIN AND WILL IN NO CIRCUMSTANCES BE SUPPLANTED  
IN AUTHORITY BY ANY OTHER GRAPHIC OR DIGITAL FORM  
OF THE PLAT. THERE MAY BE ADDITIONAL RESTRICTIONS THAT  
ARE NOT RECORDED ON THIS PLAT THAT MAY BE FOUND IN  
THE PUBLIC RECORDS OF THIS COUNTY.

### BASIS OF BEARINGS

BEARINGS SHOWN HEREON ARE BASED ON THE NORTH BOUNDARY  
OF SECTION 6, TOWNSHIP 43 SOUTH, RANGE 41 EAST, HAVING A GRID  
BEARING OF S.89°48'53"E. (MEASURED), BEARINGS SHOWN  
HEREON, REFER TO THE STATE PLANE COORDINATE SYSTEM, NORTH  
AMERICA DATUM OF 1983 (NAD 83 - 07) FOR THE EAST ZONE OF  
FLORIDA. SAID BASIS OF BEARING IS THE SAME IN THE NORTH  
AMERICAN DATUM OF 1983 (NAD 83 - 90).



4152 W. Blue Heron Blvd. Phone: (561) 444-2720  
Suite 105 www.geopointsurvey.com  
Riviera Beach, FL 33404 Licensed Business Number LB 7768

DESCRIPTION:

A PARCEL OF LAND LYING IN SECTION 12, TOWNSHIP 43 SOUTH, RANGE 40 EAST, PALM BEACH COUNTY, FLORIDA, AND BEING MORE PARTICULARLY DESCRIBED AS FOLLOWS:

COMMENCE AT THE NORTHEAST CORNER OF SECTION 1, TOWNSHIP 43 SOUTH, RANGE 40 EAST; THENCE S.01°33'05"W. ALONG THE EAST LINE OF SAID SECTION 1, A DISTANCE OF 250.33 FEET TO A POINT ON THE NORTH LINE OF THE 80 FOOT M-CANAL EASEMENT AS RECORDED IN DEED BOOK 1156, PAGE 58 OF THE PUBLIC RECORDS OF PALM BEACH COUNTY, FLORIDA AND AS SHOWN IN ROAD PLAT BOOK 6, PAGE 136 OF SAID PUBLIC RECORDS, AND AS MONUMENTED; THENCE S.88°36'57"W. ALONG SAID NORTH LINE OF THE 80 FOOT M-CANAL EASEMENT, A DISTANCE OF 3776.52 FEET TO A POINT ON THE EAST RIGHT-OF-WAY LINE OF SEMINOLE PRATT WHITNEY ROAD AS RECORDED IN OFFICIAL RECORD BOOK 1544, PAGE 378 AND OFFICIAL RECORD BOOK 1640, PAGE 1626 BOTH OF SAID PUBLIC RECORDS; THENCE S.01°42'52"W. ALONG SAID EAST RIGHT-OF-WAY LINE OF SEMINOLE PRATT WHITNEY ROAD, A DISTANCE OF 4257.61 FEET; THENCE S.88°17'08"E, A DISTANCE OF 10.00 FEET TO THE NORTHERLY CORNER OF PROPOSED ADDITIONAL RIGHT-OF-WAY OF SEMINOLE PRATT WHITNEY ROAD; THENCE S.43°17'08"E, ALONG SAID PROPOSED ADDITIONAL RIGHT-OF-WAY, A DISTANCE OF 28.28 FEET TO THE POINT OF BEGINNING; THENCE S.88°17'08"E, A DISTANCE OF 301.55 FEET; THENCE S.75°00'54"E, A DISTANCE OF 52.28 FEET; THENCE S.88°17'08"E, A DISTANCE OF 202.17 FEET; THENCE N.46°42'52"E, A DISTANCE OF 15.56 FEET; THENCE S.88°17'08"E, A DISTANCE OF 386.66 FEET; THENCE S.75°52'24"E, A DISTANCE OF 51.20 FEET; THENCE S.88°17'08"E, A DISTANCE OF 191.23 FEET TO A POINT OF CURVATURE OF A CURVE CONCAVE NORTHWESTERLY WITH A RADIUS OF 40.00 FEET; THENCE NORTHEASTERLY, ALONG THE ARC OF SAID CURVE, THROUGH A CENTRAL ANGLE OF 89°58'29", A DISTANCE OF 62.81 FEET TO A POINT OF TANGENCY; THENCE N.01°44'23"E, A DISTANCE OF 41.17 FEET; THENCE S.88°17'31"E, A DISTANCE OF 107.96 FEET TO A NON-TANGENT INTERSECTION TO A CURVE CONCAVE EASTERLY WITH A RADIUS OF 595.00 FEET, AND A RADIAL BEARING OF S.88°17'31"E. AT SAID INTERSECTION; THENCE SOUTHERLY ALONG THE ARC OF SAID CURVE THROUGH A CENTRAL ANGLE OF 06°25'48", A DISTANCE OF 66.77 FEET TO A POINT OF COMPOUND CURVATURE OF A CURVE CONCAVE NORTHEASTERLY WITH A RADIUS OF 8.00 FEET; THENCE SOUTHEASTERLY, ALONG THE ARC OF SAID CURVE, THROUGH A CENTRAL ANGLE OF 47°41'38", A DISTANCE OF 6.66 FEET TO A POINT OF REVERSE CURVATURE OF A CURVE CONCAVE SOUTHWESTERLY WITH A RADIUS OF 48.43 FEET; THENCE SOUTHEASTERLY, ALONG THE ARC OF SAID CURVE THROUGH A CENTRAL ANGLE OF 54°07'50", A DISTANCE OF 45.75 FEET TO A POINT OF TANGENCY; THENCE S.01°42'52"W, A DISTANCE OF 49.64 FEET TO A POINT OF CURVATURE OF A CURVE CONCAVE NORTHWESTERLY WITH A RADIUS OF 40.00 FEET; THENCE SOUTHWESTERLY, ALONG THE ARC OF SAID CURVE THROUGH A CENTRAL ANGLE OF 49°26'45", A DISTANCE OF 34.52 FEET TO A POINT OF TANGENCY; THENCE S.51°09'38"W, A DISTANCE OF 27.73 FEET TO A POINT OF CURVATURE OF A CURVE CONCAVE NORTHERLY WITH A RADIUS OF 40.00 FEET; THENCE WESTERLY, ALONG THE ARC SAID CURVE THROUGH A CENTRAL ANGLE OF 40°33'15", A DISTANCE OF 28.31 FEET TO A POINT OF TANGENCY; THENCE N.88°17'08"W, A DISTANCE OF 40.26 FEET TO A POINT OF CURVATURE OF A CURVE CONCAVE NORTHERLY WITH A RADIUS OF 40.00 FEET; THENCE WESTERLY, ALONG THE ARC OF SAID CURVE, THROUGH A CENTRAL ANGLE OF 34°07'19", A DISTANCE OF 23.82 FEET TO A POINT OF TANGENCY; THENCE N.54°09'49"W, A DISTANCE OF 27.38 FEET TO A POINT OF CURVATURE OF A CURVE CONCAVE SOUTHERLY WITH A RADIUS OF 10.00 FEET; THENCE WESTERLY, ALONG THE ARC OF SAID CURVE, THROUGH A CENTRAL ANGLE OF 34°07'19", A DISTANCE OF 5.96 FEET TO A POINT OF TANGENCY; THENCE N.88°17'08"W, A DISTANCE OF 537.10 FEET; THENCE S.46°42'52"W, A DISTANCE OF 15.56 FEET; THENCE N.88°17'08"W, A DISTANCE OF 276.68 FEET; THENCE N.75°52'41"W, A DISTANCE OF 51.20 FEET; THENCE N.88°17'08"W, A DISTANCE OF 329.72 FEET TO A POINT ON SAID PROPOSED ADDITIONAL RIGHT-OF-WAY OF SEMINOLE PRATT WHITNEY ROAD; THENCE CONTINUE ALONG SAID PROPOSED ADDITIONAL RIGHT-OF-WAY, FOR THE FOLLOWING FOUR (4) COURSES: 1) N.46°42'52"E, A DISTANCE OF 26.87 FEET; 2) THENCE N.01°42'52"E, A DISTANCE OF 88.00 FEET; 3) THENCE N.88°17'08"W, A DISTANCE OF 12.00 FEET; 4) THENCE N.43°17'08"W, A DISTANCE OF 26.87 FEET TO THE POINT OF BEGINNING.

CONTAINING: 4.039 ACRES, MORE OR LESS.

SURVEYOR'S NOTES:

- 1) EASEMENTS, RIGHTS-OF-WAYS, SET BACK LINES, RESERVATIONS, AGREEMENTS AND OTHER SIMILAR MATTERS TAKEN FROM OWNERSHIP AND ENCUMBRANCE REPORT PREPARED BY FOUNDERS TITLE, DATED MAY XX, 2018.
2) THIS SURVEY IS LIMITED TO ABOVE GROUND VISIBLE IMPROVEMENTS ALONG AND NEAR THE BOUNDARY LINES, AND THAT NOTHING BELOW THE GROUND WAS LOCATED INCLUDING, BUT NOT LIMITED TO FOUNDATIONS (FOOTINGS), UTILITIES, ETC. (INTERIOR OCCUPATION NOT LOCATED)
3) BEARINGS SHOWN HEREON ARE GRID BEARINGS BASED ON THE NORTH BOUNDARY OF SECTION 6, TOWNSHIP 43 SOUTH, RANGE 41 EAST, HAVING A GRID BEARING OF S.89°48'53"E. THE GRID BEARINGS, AS SHOWN HEREON, REFER TO THE STATE PLANE COORDINATE SYSTEM, NORTH AMERICA DATUM OF 1983 (NAD 83 - 07) FOR THE EAST ZONE OF FLORIDA. SAID BASIS OF BEARING IS THE SAME IN THE NORTH AMERICAN DATUM OF 1983 (NAD 83 - 90).
4) THE SUBJECT PROPERTY LIES WITHIN THE CITY OF WESTLAKE, PALM BEACH COUNTY, FLORIDA, WHERE THE FLOOD ZONE IS UNDETERMINED AT THE TIME OF THIS SURVEY.
5) THIS SURVEY IS BASED ON PREVIOUS FIELD SURVEYS, DOCUMENTS OF RECORD, FOUND MONUMENTS, EXHIBITS, AND HISTORICALLY USED CORNERS, AS WELL AS THE LEGAL DESCRIPTION SHOWING EASEMENTS LIKE UTILITIES UNDER CONSTRUCTION ARE NOT LOCATED FOR THE PURPOSE OF SHOWING THE BOUNDARY OF A PROPOSED PLAT. THE FOLLOWING ARE REFERENCE SURVEYS USED IN DETERMINING THE BOUNDARY LOCATION FOR CALLERY JUDGE GROVES:
a) THE 'M' CANAL ROAD RIGHT OF WAY MAP, RECORDED IN ROAD PLAT BOOK 6, PAGE 136.
b) BOUNDARY SURVEY OF RESIDENTIAL AT CALLERY JUDGE GROVES, PREPARED BY LIDBERG LAND SURVEYING, INC. (JOB NO.: 04-106-101C), DATED OCTOBER 5, 2007.
c) SKETCH OF SURVEY, PREPARED BY S.P. MUSICK, DATED MARCH 5, 1965.
6) ALL BEARINGS AND DISTANCES (UNITED STATES SURVEY FEET) AS SHOWN HEREON ARE AS DESCRIBED AND MEASURED UNLESS OTHERWISE NOTED. MEASUREMENTS MADE ARE TO THE ACCURACY STANDARD OF SUBURBAN OR 1 FOOT IN 7500 FEET.
7) SID AND SWCD EASEMENTS WITHIN BOUNDARY HAVE BEEN RELEASE PER O.R. 28084, PG. 0985.

LEGEND

- P.O.B. ----- POINT OF BEGINNING
O.R./O.R.B. ----- OFFICIAL RECORD BOOK
PG(s). ----- PAGE(S)
D.B. ----- DEED BOOK
P.B.C. ----- PALM BEACH COUNTY
12-43-41 ----- SECTION-TOWNSHIP-RANGE
NAD83 ----- NORTH AMERICAN DATUM 1983
SIR • ----- SET 5/8" IRON ROD LB7768
R ----- RADIUS
L ----- ARCH LENGTH
D ----- DELTA ANGLE
TYP. ----- TYPICAL
R/W ----- RIGHT-OF-WAY
LB ----- LICENSED BUSINESS
G ▽ ----- WATER GATE VALVE
FH ⚡ ----- FIRE HYDRANT
⊙ ----- UTILITY POLE
⊙ ----- SANITARY SEWER MANHOLE
⊙ ----- STORM DRAINAGE MANHOLE
⊙ ----- SIGN
---|--- ----- TOP OF BANK
---|--- ----- EDGE OF WATER
---|--- ----- CHAINLINK FENCE
---|--- ----- OVERHEAD UTILITY

THIS SURVEY WAS PREPARED WITH THE BENEFIT OF A SEARCH OF THE PUBLIC RECORDS OF PALM BEACH COUNTY, STATE OF FLORIDA, COMMENCING FROM CHICAGO TITLE INSURANCE COMPANY NUMBER 7430709-90031461 WITH AN EFFECTIVE DATE OF SEPTEMBER 20, 2013 AND CONTINUING UP TO AND INCLUDING JULY 6, 2018 AT 11:00 P.M.:

OWNER: MINTO PBLH, LLC, A FLORIDA LIMITED LIABILITY COMPANY, BY VIRTUE OF SPECIAL WARRANTY DEED, FILED OF RECORD JUNE 23, 2014, IN OFFICIAL RECORDS BOOK 28871, PAGE 505 AND QUIT CLAIM DEED, FILED OF RECORD JUNE 23, 2014, IN OFFICIAL RECORDS BOOK 28871, PAGE 511, BOTH OF THE PUBLIC RECORDS OF PALM BEACH COUNTY, FLORIDA.

ENCUMBRANCES:

- 1. MORTGAGE AND SECURITY AGREEMENT BY AND BETWEEN MINTO PBLH, LLC AND WELLS FARGO BANK, N.A., AS ADMINISTRATIVE AGENT, FILED OF RECORD MAY 9, 2016, IN OFFICIAL RECORDS BOOK 28283, PAGE 1060, TOGETHER WITH ABSOLUTE ASSIGNMENT OF LEASES AND RENTS, FILED OF RECORD MAY 9, 2016, IN OFFICIAL RECORDS BOOK 28283, PAGE 1094; ASSIGNMENT OF AGREEMENTS AFFECTING REAL ESTATE, FILED OF RECORD MAY 9, 2016, IN OFFICIAL RECORDS BOOK 28283, PAGE 1114; MORTGAGE MODIFICATION AGREEMENT, FILED OF RECORD DECEMBER 29, 2016, IN OFFICIAL RECORDS BOOK 28798, PAGE 1467; MORTGAGE SPREADER AGREEMENT, FILED OF RECORD FEBRUARY 16, 2017, IN OFFICIAL RECORDS BOOK 28896, PAGE 893; MORTGAGE MODIFICATION AND FUTURE ADVANCE AGREEMENT, FIELD OF RECORD JANUARY 3, 2018, IN OFFICIAL RECORDS BOOK 29564, PAGE 571, ALL OF THE PUBLIC RECORDS OF PALM BEACH COUNTY, FLORIDA.
2. FINANCING STATEMENT FORM UCC-1, BY AND BETWEEN MINTO PBLH, LLC AND WELLS FARGO BANK, N.A., AS ADMINISTRATIVE AGENT, FILED OF RECORD MAY 9, 2016, IN OFFICIAL RECORDS BOOK 28283, PAGE 1134; TOGETHER WITH FINANCING STATEMENT FORM UCC-3, FILED OF RECORD JUNE 21, 2016, IN OFFICIAL RECORDS BOOK 28384, PAGE 733; FINANCING STATEMENT FORM UCC-3, FILED OF RECORD JUNE 22, 2016, IN OFFICIAL RECORDS BOOK 28387, PAGE 509; AND FINANCING STATEMENT FORM UCC-3, FILED OF RECORD FEBRUARY 16, 2017, IN OFFICIAL RECORDS BOOK 28896, PAGE 903, ALL OF THE PUBLIC RECORDS OF PALM BEACH COUNTY, FLORIDA.

EASEMENTS AND OTHER MATTERS AFFECTING TITLE:

- 1. CONTRACT BETWEEN WEST PALM BEACH WATER COM. AND INDIAN TRAIL RANCH, INC., RECORDED IN DEED BOOK 1156, PAGE 36, OF THE PUBLIC RECORDS OF PALM BEACH COUNTY, FLORIDA. (DOES NOT AFFECTS THE PARCEL)
2. MUTUAL RIGHT-OF-WAY AGREEMENT DATED APRIL 1, 1966 AND RECORDED APRIL 1, 1966, IN OFFICIAL RECORDS BOOK 1354, PAGE 47, AS ASSIGNED IN OFFICIAL RECORDS BOOK 2606, PAGE 1023, BOTH OF THE PUBLIC RECORDS OF PALM BEACH COUNTY, FLORIDA. (DOES NOT AFFECTS THE PARCEL)
3. RESERVATION OF RIGHTS AS CONTAINED WITHIN QUIT CLAIM DEED AND AGREEMENT FOR RESERVATION OF RIGHTS, DATED JANUARY 30, 2003, RECORDED FEBRUARY 3, 2003, IN OFFICIAL RECORDS BOOK 14742, PAGE 1196, AS AFFECTED BY PARTIAL RELEASE FROM THE SEMINOLE IMPROVEMENT DISTRICT, RECORDED IN OFFICIAL RECORDS BOOK 28084, PAGE 985, BOTH OF THE PUBLIC RECORDS OF PALM BEACH COUNTY, FLORIDA. (DOES NOT AFFECTS THE PARCEL)
4. INTERLOCAL AGREEMENT BETWEEN PALM BEACH COUNTY AND SEMINOLE IMPROVEMENT DISTRICT RECORDED IN OFFICIAL RECORDS BOOK 20252, PAGE 184, OF THE PUBLIC RECORDS OF PALM BEACH COUNTY, FLORIDA. (NOT A MATTER OF SURVEY-BLANKET EASEMENT)
5. TERMS, PROVISIONS AND EASEMENTS CONTAINED IN THAT CERTAIN WARRANTY DEED RECORDED SEPTEMBER 25, 1956 IN DEED BOOK 1156, PAGE 58, OF THE PUBLIC RECORDS OF PALM BEACH COUNTY, FLORIDA. (DOES NOT AFFECTS THE PARCEL)
6. MATTERS SHOWN ON THE MAP OF M-CANAL ROAD, RECORDED IN ROAD PLAT BOOK 6, PAGE 136, OF THE PUBLIC RECORDS OF PALM BEACH COUNTY, FLORIDA. (DOES NOT AFFECTS THE PARCEL)
7. RECORDED NOTICE OF ENVIRONMENTAL RESOURCE PERMIT BY SOUTH FLORIDA WATER MANAGEMENT DISTRICT, RECORDED AUGUST 13, 2015, IN OFFICIAL RECORDS BOOK 27737, PAGE 15, OF THE PUBLIC RECORDS OF PALM BEACH COUNTY, FLORIDA. (DOES NOT AFFECTS THE PARCEL)
8. COLLATERAL ASSIGNMENT OF DECLARANT'S RIGHTS BY AND BETWEEN MINTO PBLH, LLC AND WELLS FARGO BANK, NA., RECORDED JANUARY 25, 2018, IN OFFICIAL RECORDS BOOK 29611, PAGE 673, OF THE PUBLIC RECORDS OF PALM BEACH COUNTY, FLORIDA. (DOES NOT AFFECTS THE PARCEL)
9. SEMINOLE PRATT WHITNEY ROAD RURAL PARKWAY EASEMENT, BY MINTO PBLH, LLC TO SEMINOLE IMPROVEMENT DISTRICT AND PALM BEACH COUNTY, RECORDED OCTOBER 30, 2015, IN OFFICIAL RECORDS BOOK 27898, PAGE 1321, OF THE PUBLIC RECORDS OF PALM BEACH COUNTY, FLORIDA. (SHOWN)
10. UTILITY EASEMENT BY SEMINOLE IMPROVEMENT DISTRICT TO PALM BEACH COUNTY WATER UTILITIES DEPARTMENT, RECORDED JUNE 6, 2016, IN OFFICIAL RECORDS BOOK 28347, PAGE 411, OF THE PUBLIC RECORDS OF PALM BEACH COUNTY, FLORIDA. (DOES NOT AFFECTS THE PARCEL)
11. LICENSE FOR SEMINOLE PRATT WHITNEY ROAD CROSSINGS BY PALM BEACH COUNTY, RECORDED JUNE 29, 2017, IN OFFICIAL RECORDS BOOK 29189, PAGE 1445, OF THE PUBLIC RECORDS OF PALM BEACH COUNTY, FLORIDA. (DOES NOT AFFECTS THE PARCEL)
12. UTILITY AND ACCESS EASEMENT BY MINTO PBLH, LLC AND FLORIDA POWER & LIGHT COMPANY, RECORDED AUGUST 10, 2017, IN OFFICIAL RECORDS BOOK 29283, PAGE 1333, TOGETHER WITH AMENDMENT TO UTILITY AND ACCESS EASEMENT, RECORDED APRIL 30, 2018, IN OFFICIAL RECORDS BOOK 29817, PAGE 650, BOTH OF THE PUBLIC RECORDS OF PALM BEACH COUNTY, FLORIDA. (DOES NOT AFFECTS THE PARCEL)
13. SEMINOLE PRATT WHITNEY RURAL PARKWAY MAINTENANCE AGREEMENT, BY AND BETWEEN MINTO PBLH, LLC AND SEMINOLE IMPROVEMENT DISTRICT, RECORDED MAY 10, 2018, IN OFFICIAL RECORDS BOOK 29842, PAGE 25, OF THE PUBLIC RECORDS OF PALM BEACH COUNTY, FLORIDA. (DOES NOT AFFECTS THE PARCEL)

WESTLAKE BOUNDARY SURVEY PROPOSED WATERS EDGE DRIVE

Table with columns: REVISIONS (No., Date, Description, Dwn.), Prepared For: MINTO COMMUNITIES, LLC, Last Date of Field Survey: 07/23/18, SURVEYOR'S CERTIFICATE, Luis J. Ortiz, FLORIDA PROFESSIONAL SURVEYOR & MAPPER NO. LS7006, Sheet No. 1 of 2 Sheets.

GeoPoint Surveying, Inc. logo and contact information: 4152 W. Blue Heron Blvd., Suite 105, Riviera Beach, FL 33404. Phone: (561) 444-2720, www.geopointsurveying.com, Licensed Business Number LB 7768.



FILED BY: SERGIO TACONADO ON: 8/14/2018 3:28 PM LAST SAVED BY: SERGIO ON: 8/14/2018 3:33 PM

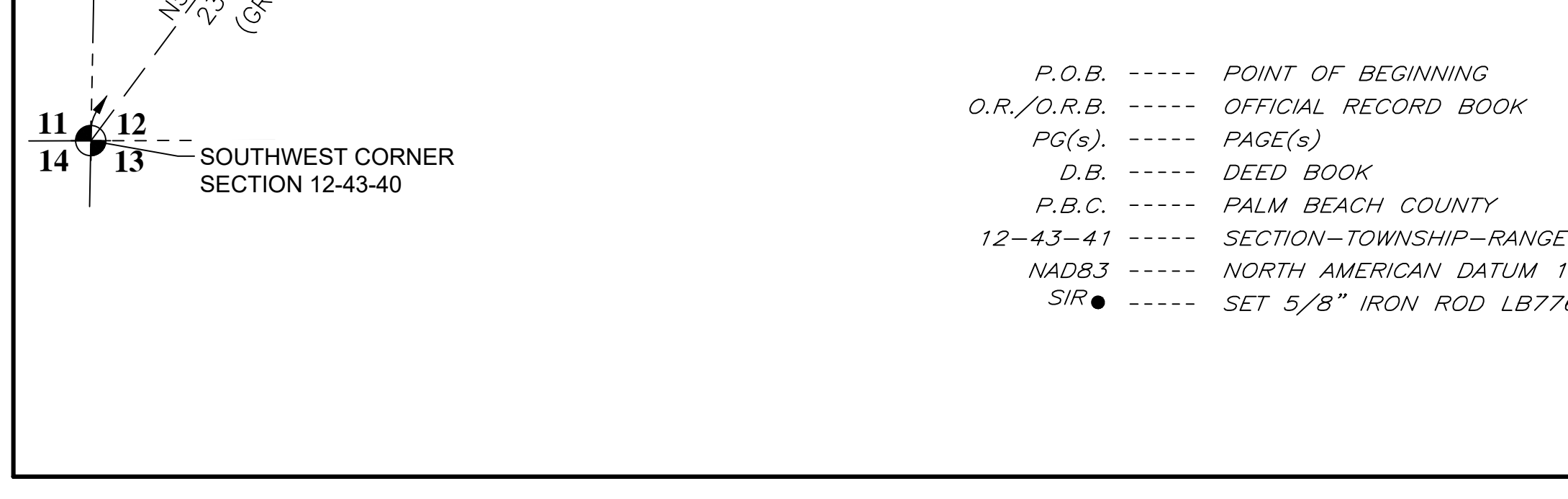
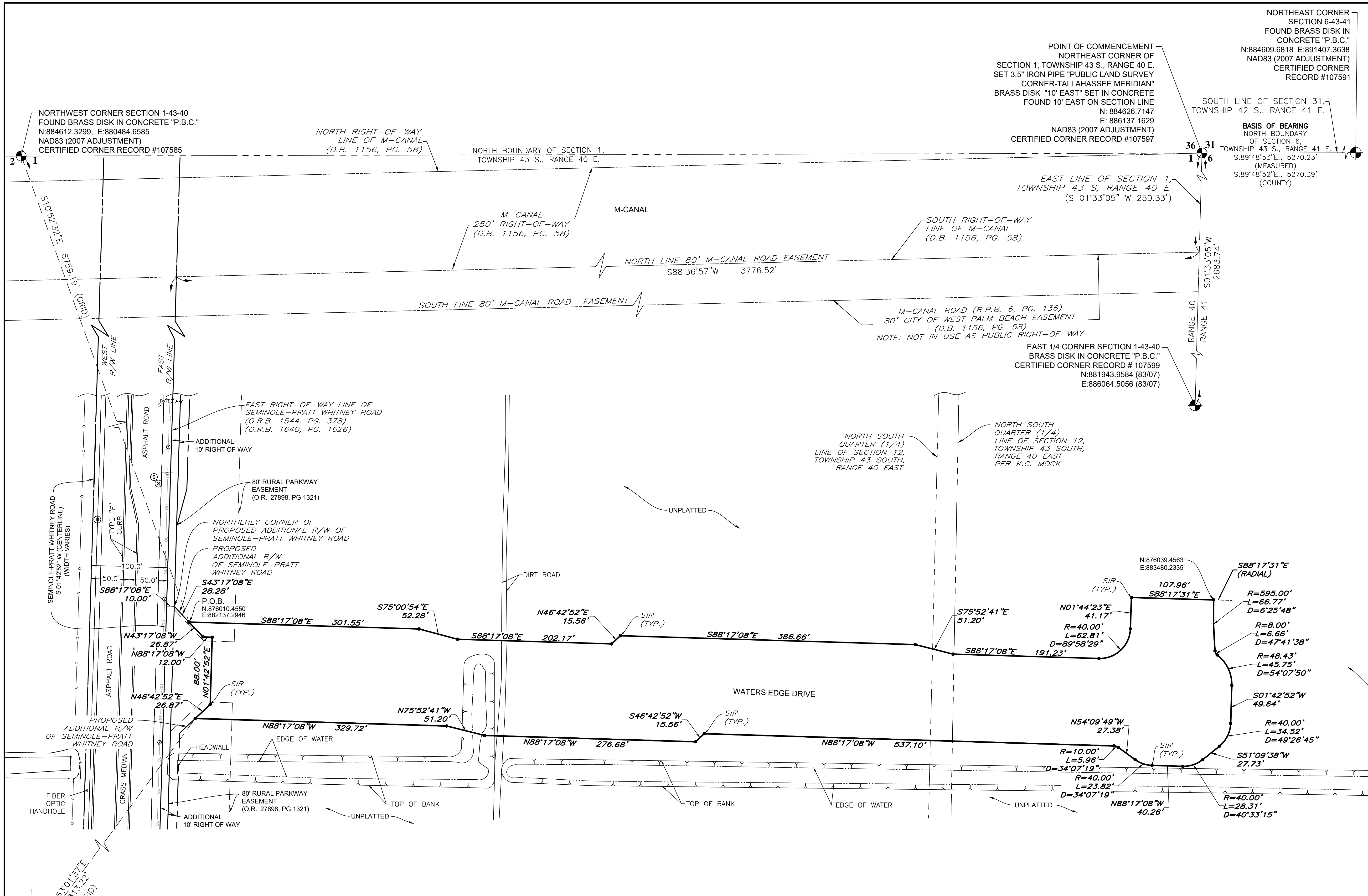
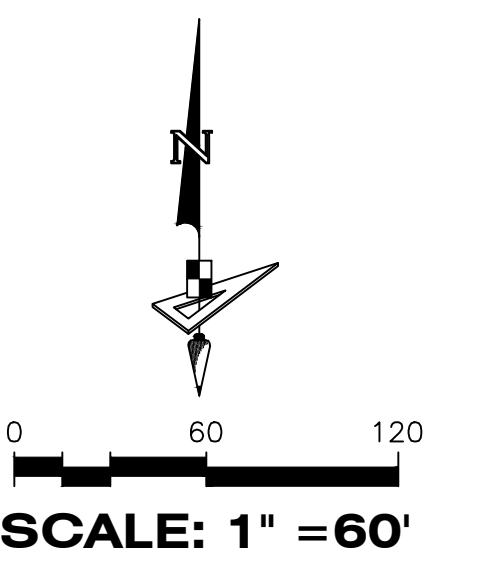
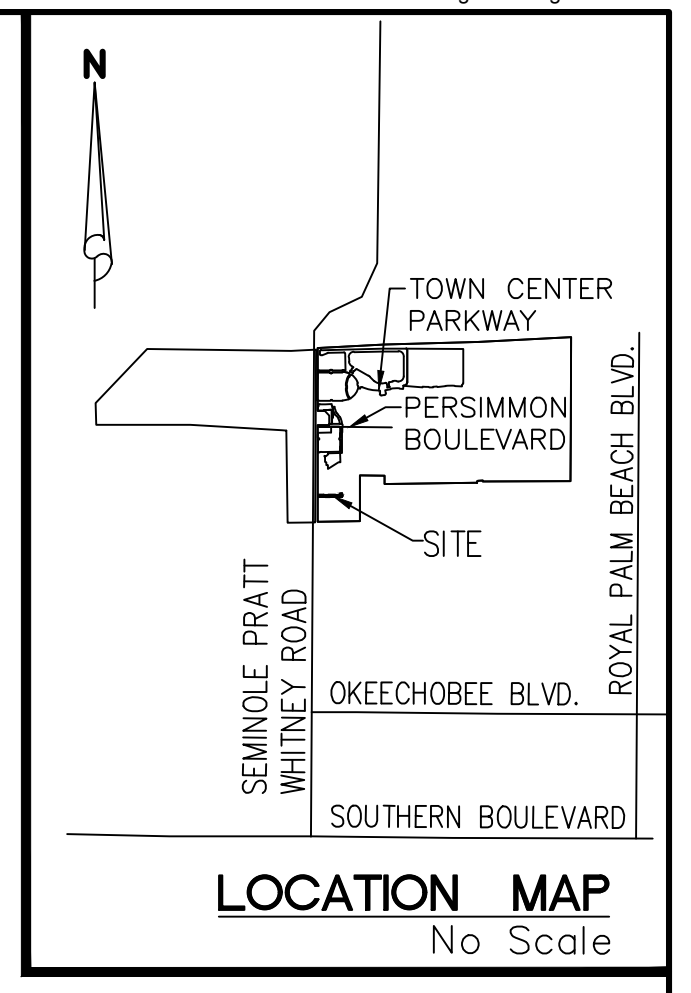

### WESTLAKE BOUNDARY SURVEY PROPOSED WATERS EDGE DRIVE

| REVISIONS |      | Prepared For: MINTO COMMUNITIES, LLC |      |
|-----------|------|--------------------------------------|------|
| No.       | Date | Description                          | Dwn. |
|           |      |                                      |      |
|           |      |                                      |      |
|           |      |                                      |      |

**LAST DATE OF FIELD SURVEY: 07/23/18**  
**SURVEYOR'S CERTIFICATE**  
 This certifies that a survey of the herein described property was made under my supervision and meets the Standards of Practice set forth by the Florida Board of Professional Surveyors & Mappers in Chapter 5J-17.050, Florida Administrative Code, pursuant to Section 472.027, Florida Statutes.

**Luis J. Ortiz**  
 FLORIDA PROFESSIONAL SURVEYOR & MAPPER NO. **LS7006**  
 Check: GAR P.C.: --- Field Book: ---

4152 W. Blue Heron Blvd.  
Suite 105  
Riviera Beach, FL 33404

Phone: (561) 444-2720  
www.geopointsurvey.com  
Licensed Business Number LB 7768

Drawn: SWM Date: 07/24/18 Data File: ---  
 Check: GAR P.C.: --- Field Book: ---

**Sheet No. 2 of 2 Sheets**

WESTLAKE BOUNDARY SURVEY PROPOSED WATERS EDGE DRIVE CS-E4 BS-DWG PLOTTED BY: SERGIO TACORDA ON: 8/14/2018 2:28 PM LAST SAVED BY: SERGIO ON: 8/14/2018 2:33 PM



## CITY OF WESTLAKE

### Engineering Department

4001 Seminole Pratt Whitney Road

Westlake, Florida 33470

Phone: (561) 530-5880

[www.westlakegov.com](http://www.westlakegov.com)

- 
1. **DATE:** 8/22/2018
  2. **PETITION NUMBER:** ENG-2018-13
  3. **DESCRIPTION:** Waters Edge ROW Plat  
**APPLICANT:** Minto PBLH, LLC  
**OWNER:** Minto PBLH, LLC  
**REQUEST:** Plat & Boundary Survey Review  
**LOCATION:** Westlake, Florida
  4. **STAFF REVIEW:** **APPROVAL LETTER**

This is the second review of this Plat and Boundary Survey. This review is done for compliance with Chapter 177 Florida Statutes, and the City of Westlake's codes and ordinances. Following are our comments:

**Boundary Survey Comments:**

All of our previous comments have been adequately addressed.

**Plat Comments:**

All of our previous comments have been adequately addressed. The plat is now in compliance with Chapter 177 Florida Statutes.

---

This letter has been prepared by the following individual, in association with their consultants and subconsultants:

A handwritten signature in blue ink, appearing to read "Suzanne Dombrowski".

Suzanne Dombrowski, P.E.

Chen Moore and Associates

Tel: 561.746.6900 x 1035

Email: [sdombrowski@chenmoore.com](mailto:sdombrowski@chenmoore.com)

## **Tenth Order of Business**

## District 15 City of Westlake

### Monthly Report: September 2018



| Calls for Service                       | Monthly    |
|---|------------|
| Business/Residence Checks               | 240        |
| Traffic Stops                           | 78         |
| Calls for Service<br>(Excluding 1061's) | 129        |
| <b>All CAD Calls – Total*</b>           | <b>369</b> |

| Traffic Summary                  | Monthly   |
|----------------------------------|-----------|
| Warnings<br>(Written and Verbal) | 56        |
| Citations                        | 18        |
| <b>Total</b>                     | <b>74</b> |

Data Source: CrimeView Dashboard  
\*Omit Miscellaneous Calls

**Summary:** During the month, there were 369 generated calls within the district. 86% of these calls were self-initiated.

| Crimes                           | Monthly  |
|----------------------------------|----------|
| Murder                           | 0        |
| Sexual Assault                   | 0        |
| Robbery                          | 0        |
| Burglary - Residential           | 0        |
| Burglary - Vehicle               | 0        |
| Burglary - Business/Construction | 0        |
| Theft                            | 0        |
| Motor Vehicle Theft              | 0        |
| Vandalism                        | 0        |
| Fire                             | 0        |
| <b>Total</b>                     | <b>0</b> |

## **Eleventh Order of Business**





**Fire Rescue**

Chief Michael Mackey

405 Pike Road

West Palm Beach, FL 33411

(561) 616-7000

www.pbcgov.com



**Palm Beach County  
Board of County  
Commissioners**

Melissa McKinlay, Mayor

Mack Bernard, Vice Mayor

Hal R. Valeche

Paulette Burdick

Dave Kerner

Steven L. Abrams

Mary Lou Berger

**County Administrator**

Verdenia C. Baker

October 2, 2018

Ken Cassel, Village Manager  
City of Westlake  
4001 Seminole Pratt Whitney Rd.  
Westlake, FL 33470

Dear Mr. Cassel:

Enclosed is the Response Time Report for the City of Westlake for the month of September 2018.

If you have any questions of concerns, please contact me at 561-214-3263

Sincerely,

A handwritten signature in blue ink, appearing to read "William Rowley".

William Rowley, District Chief  
Palm Beach County Fire Rescue



10/1/2018

# Palm Beach County Fire Rescue

## Westlake Response Time Report

### 20180901 to 20180930

| Event #                        | Station | Location of Event                 | Date       | Received | Entered  | Dispatch | Enroute  | Oncene   | Close    | Disp Hand      | Turnout        | Travel         | Resp Time*     |
|--------------------------------|---------|-----------------------------------|------------|----------|----------|----------|----------|----------|----------|----------------|----------------|----------------|----------------|
| <b>Emergency Calls:</b>        |         |                                   |            |          |          |          |          |          |          |                |                |                |                |
| F18154453                      | 22      | SEMINOLE PRATT WHITNEY RD WLK     | 09/13/2018 | 18:27:49 | 18:28:16 | 18:28:25 | 18:29:54 | 18:32:38 | 19:21:19 | 0:00:36        | 0:01:29        | 0:02:44        | 0:04:49        |
| F18156772                      | 22      | SEMINOLE PRATT WHITNEY RD WLK     | 09/17/2018 |          | 18:21:33 | 18:22:20 | 18:23:54 | 18:27:15 | 19:19:36 | 0:01:12        | 0:01:34        | 0:03:21        | 0:06:07        |
| F18158409                      | 26      | 140TH AVE N WLK                   | 09/20/2018 | 15:15:03 | 15:15:22 | 15:15:30 | 15:16:31 | 15:22:04 | 16:24:46 | 0:00:27        | 0:01:01        | 0:05:33        | 0:07:01        |
| F18162327                      | 26      | 140TH AVE N WLK                   | 09/27/2018 | 12:40:51 | 12:42:14 | 12:42:23 | 12:44:08 | 12:46:37 | 13:47:31 | 0:01:32        | 0:01:45        | 0:02:29        | 0:05:46        |
| <b>Average Response Times:</b> |         |                                   |            |          |          |          |          |          |          | <b>0:00:57</b> | <b>0:01:27</b> | <b>0:03:32</b> | <b>0:05:56</b> |
| <b>Non Emergency Calls:</b>    |         |                                   |            |          |          |          |          |          |          |                |                |                |                |
| F18149573                      | 26      | 140TH AVE N WLK                   | 09/05/2018 |          | 12:03:24 | 12:03:34 | 12:04:59 | 12:21:47 | 12:27:59 | 0:00:35        | 0:01:25        | 0:16:48        | 0:18:48        |
| F18155215                      | 22      | WHIPPORWILL CIR/BUTTONBUSH DR WLK | 09/15/2018 |          | 01:44:47 | 01:44:58 | 01:46:44 | 01:52:34 | 02:02:32 | 0:00:36        | 0:01:46        | 0:05:50        | 0:08:12        |

**Total number of Events: 6**

\*Represents call received to arrival. If there is no received time, the County annual average call received to call entered time is used.



10/1/2018

# Palm Beach County Fire Rescue

## Westlake - # of Calls by Type

20180901 to 20180930

| <u>Type - Situation Dispatched</u> | <u># of Incidents</u> |
|------------------------------------|-----------------------|
| Medical Calls:                     | 4                     |
| Assists\Investigations:            | 1                     |
| Alarms:                            | 1                     |
| <b>Total number of Events:</b>     | <b>6</b>              |

### Calls by Situation Dispatched

